

Project item
Please contact our technical support
+1 508 485 2244
<https://www.novotechnik.com/salesupport.php>

NOVOHALL
Rotary Sensor
Non-contacting

RSC-2800
Incremental
Industrial

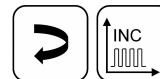

Special Features

- Non-contacting, magnetic technology
- Measuring range 360°
- Available with push-on coupling or marked shaft
- Simple mounting
- Protection class IP54, IP65, IP67
- Long life
- Very small hysteresis
- High resolution 12 bits
- Linearity <math>< \pm 0.5 \%</math>
- Other configurations see separate data sheets

Applications

- Manufacturing Engineering (textile machinery, packaging machinery, sheet metal and wire machinery)
- Automation technology
- Medical Engineering

The RSC-2800 sensor utilizes a contactless magnetic measurement technology to determine the measured angle. Unlike conventional Hall sensors, the orientation of the magnetic field is measured. The position information corresponding to the angular position is transmitted via a variety of analog and digital interfaces (see separate data sheets).

The housing is made of a special high grade temperature-resistant plastic material. Elongated slots allow simplicity in mounting together with ease of mechanical adjustment.

Three shaft options are available, including a push-on coupling option that ensures fast and simple installation.

Description

Material	Housing: high grade, temperature resistant plastic PPS-GF40/SF50 Shaft: SS X8CrNiS18-9 1.4305 / AISI 303
Mounting	With 2 screws M4 and washers
Max. fastening torque of mounting screws	max. 180 Ncm
Bearing	Sintered bronze bushing
Electrical connection	Cable 4x 2x 0.25 mm ² (AWG 24), TPE, shielded / Connector M12x1, A-coded with cable L = 0.15 m

Mechanical Data

Dimensions	See dimension drawing
Mechanical travel	continuous
Permitted shaft load static or dynamic	20 N (axial / radial)
Torque	0.15 Ncm (IP54), 0.5 Ncm (IP65), 1.0 Ncm (IP67)
Weight (w/o connection)	approx. 50 g

Ordering Specifications

Ordering Specifications

Preferred types printed in bold

- Delivery time up to 25 pcs. within 10 working days EXW
- Best low-volume pricing

Interface

5: Incremental Interface A / B / Z

Interface parameters

- 15: Ub = 5 VDC, output RS422, TTL-compatible
- 35: Ub = 24 VDC, output RS422, TTL-compatible
- 39: Ub = 24 VDC, HTL-compatible, push-pull

On request:

High side and low side outputs

UVW signals instead of ABZ signals for motor commutation

Absolute position at Power On (Power on burst)

Electrical connection

- 432: Cable, 8-pole, shielded, L = 1 m
 - 531: Connector M12x1, 8-pin, with cable, shielded, L = 0.15 m
- Cable versions and assembled connectors on request

R S C - 2 8 3 2 - 2 1 2 - 5 3 5 - 4 3 2

Series

Mechanical version

- 2802: 6 mm shaft with flattening, IP54
 - 2832: 6 mm shaft with flattening, IP65**
 - 2862: 6 mm shaft with flattening, IP67
 - 2821: push-on coupling, IP54
 - 2841: push-on coupling, IP65**
 - 2871: push-on coupling, IP67
- Other shaft configurations on request

Resolution

- 12: 1024 ppr - 4096 counts (after quadrature)
 - 11: 512 ppr - 2048 counts (after quadrature)
 - 10: 256 ppr - 1024 counts (after quadrature)
 - 09: 128 ppr - 512 counts (after quadrature)
- Other resolutions on request

Interface

2: Digital Interface

Drawing

CAD data see
www.novotechnik.de/en/download/cad-
data/

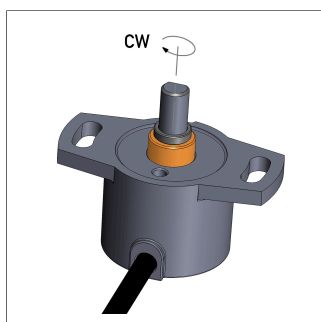
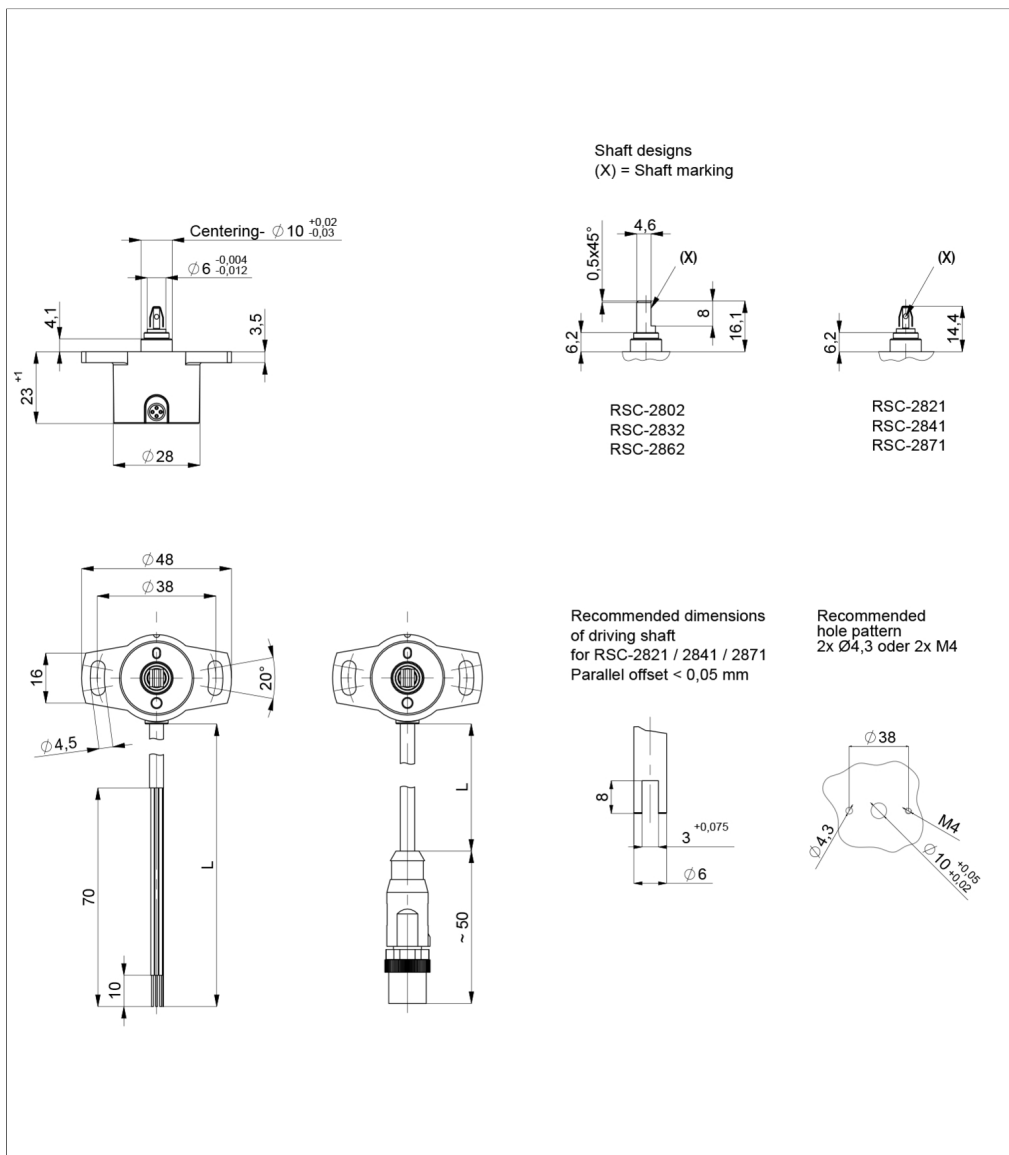

When the marking of the shaft is pointing away from the electrical outlet, the output is in the vicinity of the reference pulse (Z).
 Rotational direction CW: A leads before B.

Technical Data

Type	RSC-28__2__-51__-__	RSC-28__2__-535__-__	RSC-28__2__-539__-__
	Supply Voltage 5 VDC, TTL	Supply Voltage 24 VDC, TTL	Supply Voltage 24 VDC, HTL
Measuring range	360°		
Outputs	A+ / A-, B+ / B-, Z+ / Z-		
Level	RS-422, TTL compatible	RS-422, TTL compatible	HTL compatible, Push-Pull
Length Z-pulse	90° electrical, distance between 2 edges A/B		
Pulses per revolution	1024 / 512 / 256 / 128 ppr		
Counts per revolution	4096 / 2048 / 1024 / 512 after quadrature		
Minimum edge separation	8 µs		
Min. input frequency of counter input	32 kHz		
Independent linearity	typ. ±0.5 %FS		
Repeatability	≤ ±0.2°		
Hysteresis	≤ ±0.7°, lower hysteresis on request		
Temperature error	±0.375 %FS		
Supply voltage Ub	5 VDC (4.5 ... 5.5 VDC)	24 VDC (18 ... 30 VDC)	24 VDC (18 ... 30 VDC)
Current consumption w/o load	typ. 20 mA	typ. 10 mA	typ. 10 mA
Polarity protection	yes (supply lines)		
Short circuit protection	yes (all outputs vs. GND and supply voltage)	yes (all outputs vs. GND)	yes (all outputs vs. GND and supply voltage)
Ohmic load at outputs	≥ 120 Ω per channel A / B / Z		
Insulation resistance (500 VDC)	≥ 10 MΩ		
Environmental Data			
Vibration IEC 60068-2-6	20 g, 5 ... 2000 Hz, Amax = 0.75 mm		
Shock IEC 60068-2-27	50 g, 6 ms		
Protection class DIN EN 60529	IP54 / IP65 / IP67		
Operating temperature	-40 ... +85°C -25 ... +85°C (connector M12)		
Life	> 50 Mio. movements (mechanically)		
Functional safety	If you need assistance in using our products in safety-related systems, please contact us		
MTTF (IEC 60050)	246 years	126 years	126 years
EMC Compatibility			
EN 61000-4-2 ESD (contact/air discharge)	4 kV, 8 kV		
EN 61000-4-3 Electromagnetic fields (RFI)	10 V/m		
EN 61000-4-4 Fast transients (burst)	1 kV		
EN 61000-4-6 Cond. disturbances (HF fields)	10 V eff.		
EN 55016-2-3 Radiated disturbances	Industrial and residential area		

FS = Full scale: Signal span according to electrical measuring range

Connection Assignment

Signal	Cable code 4__	Connector code 5__
Supply voltage Ub	WH	Pin 1
GND	BN	Pin 2
A-	GN	Pin 3
A+	YE	Pin 4
B-	GY	Pin 5
B+	PK	Pin 6
Z-	RD	Pin 8
Z+	BU	Pin 7
Connect cable shielding to GND		

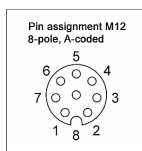

Technical Data

Protocol

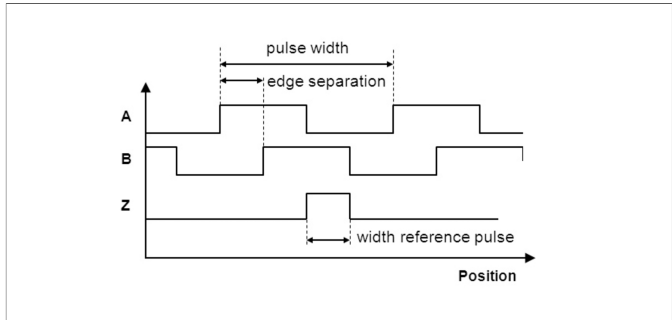

Connection

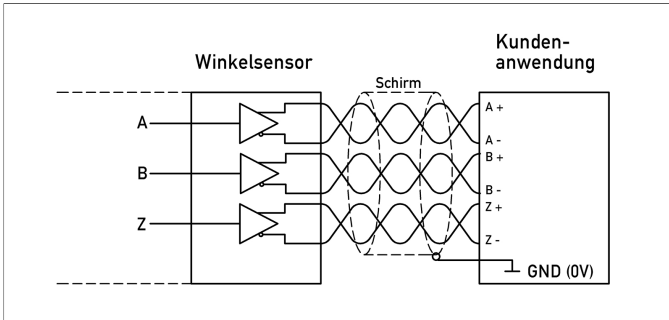

Sensor Mounting

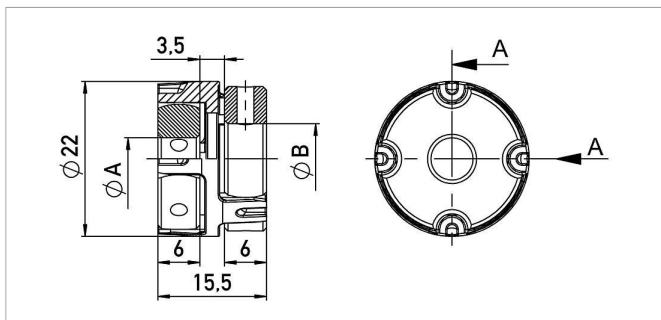
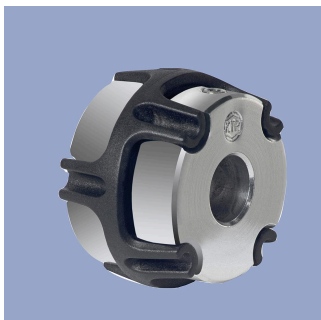

Z-106-G_
Backlash-free, double cardanic shaft coupling for $\varnothing 6$ mm to $\varnothing 6$ mm, $\varnothing 6.35$ mm or $\varnothing 10$ mm, mounting via 2 threaded pins with internal hexagon

Material Aluminium, PEEK
Operating temp. $-40 \dots +160^\circ\text{C}$
Transferable torque ≤ 1 Nm
Displacement rad. ≤ 0.1 mm, angl. $\leq 0.45^\circ$

P/N	Type	$\varnothing A / \varnothing B$ [mm]
400103910	Z-106-G-6	6 / 6
400103912	Z-106-G-6,35	6 / 6.35
400103913	Z-106-G-10	6 / 10

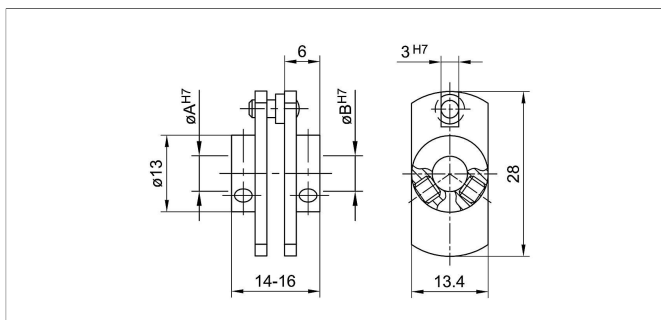
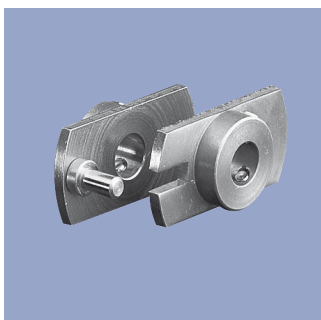

Z-104-G-6
Fork coupling with low backlash for $\varnothing 6$ mm. Mounting with 2 cylinder head screws M3 with internal hexagon. Angle screwdriver DIN 911 AF 1.5 included in delivery.

Material SS, ground driving pin
Displacement ≤ 1 mm

P/N	Type	$\varnothing A / \varnothing B$ [mm]
400005690	Z-104-G-6	6 / 6

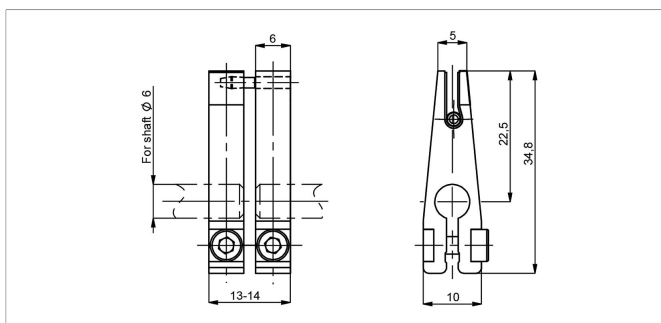
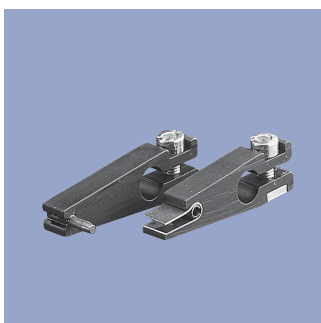

Z-105-G-6
Backlash-free fork coupling for $\varnothing 6$ mm. Mounting with 1 cylinder head screw M3 with internal hexagon. Angle screwdriver DIN 911 AF 2.5 included in delivery.

Material Aluminium, anodized (black)
Driving pin and spring hardened
Transferable torque ≤ 5 Ncm
Displacement ≤ 1 mm

P/N	Type
400005691	Z-105-G-6

Connector System M12

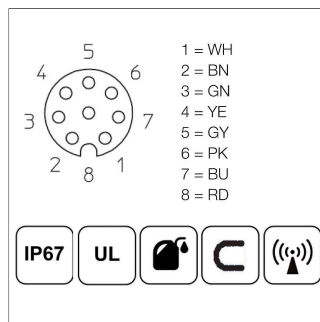
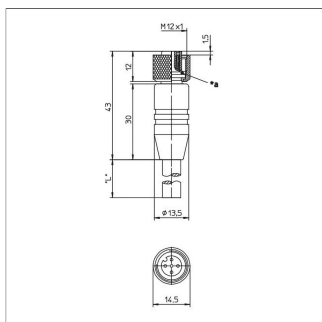

EEM-33-86/90/92
M12x1 Mating female connector, 8-pin, straight, A-coded, with molded cable, shielded, IP67, open ended

Plug housing PA
Cable sheath PUR, Ø = max. 8 mm, -25 ... +80°C (moved), -50 ... +80°C (fixed)
Lead wires PP, 0.25 mm²

P/N	Type	Length
400005629	EEM-33-86	2 m
400005635	EEM-33-90	5 m
400005637	EEM-33-92	10 m



Protection class IP67 DIN EN 60529



Protection class IP68 DIN EN 60529



Very good Electromagnetic Compatibility (EMC) and shield systems



Very good resistance to oils, coolants and lubricants



Suited for applications in dragchains



UL - approved



CAN-Bus

Connecting Options on request



- M12 connector**
- Customized lengths
 - 3-, 4-, 6- and 8-pole versions
 - Protection class IP68
 - Ordering codes of standard versions see ordering specifications

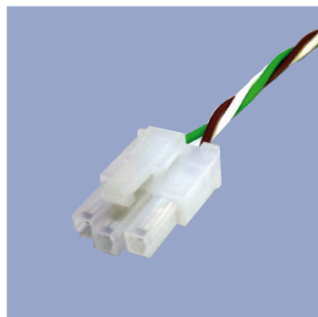

- Molex Mini Fit jr.**
- Customized length and lead wires
 - 3-, 4- and 6-pole versions
 - On request



- Tyco AMP Super Seal**
- Pin- and bushing housing
 - Customized lengths
 - 3-, 4- and 6-pole versions
 - Protection class IP67
 - On request



- Molex Mini Fit jr.**
- Customized length and lead wires
 - 3-, 4- and 6-pole versions
 - On request



- Deutsch DTM 04**
- Pin- and bushing housing
 - Customized lengths
 - 3-, 4- and 6-pole versions
 - Protection class IP67
 - On request



- ITT Cannon Sure Seal connector**
- Customized lengths
 - 3-, 4- and 6-pole versions
 - Protection class IP67
 - On request

Novotechnik U.S., Inc.
155 Northboro Road

Southborough, MA 01772
Phone 508 485 2244
Fax 508 485 2430
info@novotechnik.com
www.novotechnik.com



© Mar 20, 2026

The specifications contained in our datasheets are intended solely for informational purposes. The documented specification values are based on ideal operational and environmental conditions and can vary significantly depending on the actual customer application. Using our products at or close to one or more of the specified performance ranges can lead to limitations regarding other performance parameters. It is therefore necessary that the end user verifies relevant performance parameters in the intended application. We reserve the right to change product specifications without notice.