

**NOVOHALL
Rotary Sensor
Touchless**

**RFE-3200
Ratiometric
Mobile Applications**

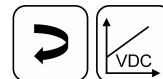

Special Features

- Touchless hall technology
- Electrical range up to 360°
- 2 part design, mechanically decoupled
- High protection class IP67, IP68, IP69K
- Resolution up to 12 bit
- Wear-free
- Temperature range -40 °C to +125 °C
- Single and dual-channel versions
- Optimized for use in mobile applications with highest EMC requirements such as ISO pulses and high interferences to ISO 11452 and ECE-Standard
- Suitable for safety-related applications according to DIN EN ISO 13849
- Other configurations see separate data sheets

Applications

- Mobile working machines (industrial trucks, construction machinery, agricultural and forestry machinery)
- Marine applications

The 2 part design consisting of sensor and magnetic position marker offers great flexibility when mounting. The absence of shaft and bearing makes the assembly much less sensitive to axial and radial application tolerances - separate couplings are obsolete. Measurements can be made transmissively through any non-ferromagnetic material.

With its completely encapsulated electronics the sensor is perfectly suited for use in harsh environments.

Single and dual-channel versions are available and suitable for use in safety-related applications.

Description

Material	Housing: high grade, temperature resistant plastic PBT GF30 with SS inserts
Mounting	With 2 pan head screws M4x18 (included in delivery)
Fastening torque of mounting	max. 200 Ncm
Electrical connection	6-pin MQS-connector, code A, tinned contact according to drawing AMP-114-18063-126, Index A1 (Connector: AMP P/N 1-967616-1)

Mechanical Data

Dimensions	See dimension drawing
Mechanical travel	continuous
Weight	approx. 50 g

Ordering Specifications

Ordering Specifications

Preferred types printed in bold

- Delivery time up to 25 pcs. within 10 working days EXW
- Best low-volume pricing

Supply voltage U_b

2: $U_b = 5$ VDC

Output signal

1: 5 ... 95% ratiometric to supply voltage U_b (0.25 ... 4.75 VDC)

2: 10 ... 90% ratiometric to supply voltage U_b (0.5 ... 4.5 VDC)

Output characteristic

1: Rising characteristic cw

2: Rising characteristic ccw

3: Crossed outputs, channel 1 rising cw (partly redundant)

4: Crossed outputs, channel 1 rising cw (fully redundant)

Other output characteristics on request

Electrical connection

521: Connector AMP MQS 6-pin, male

R F E - 3 2 0 1 - 6 3 6 - 2 1 1 - 5 2 1

Series

Mechanical version
3201: Standard design

Measuring range

03: Angle 0° ... 30° min.

...

06, 12, 18, 24, 36

...

36: Angle 0° ... 360° max.

Other angles on request

Number of channels

6: One-channel version (1x supply voltage U_b , 1x output)

7: Partly redundant version (1x supply voltage U_b , 2x output)

8: Fully redundant version (2x supply voltage U_b , 2x output)

Accessories included in delivery

- 2x Pan head screws M4x18

Drawing

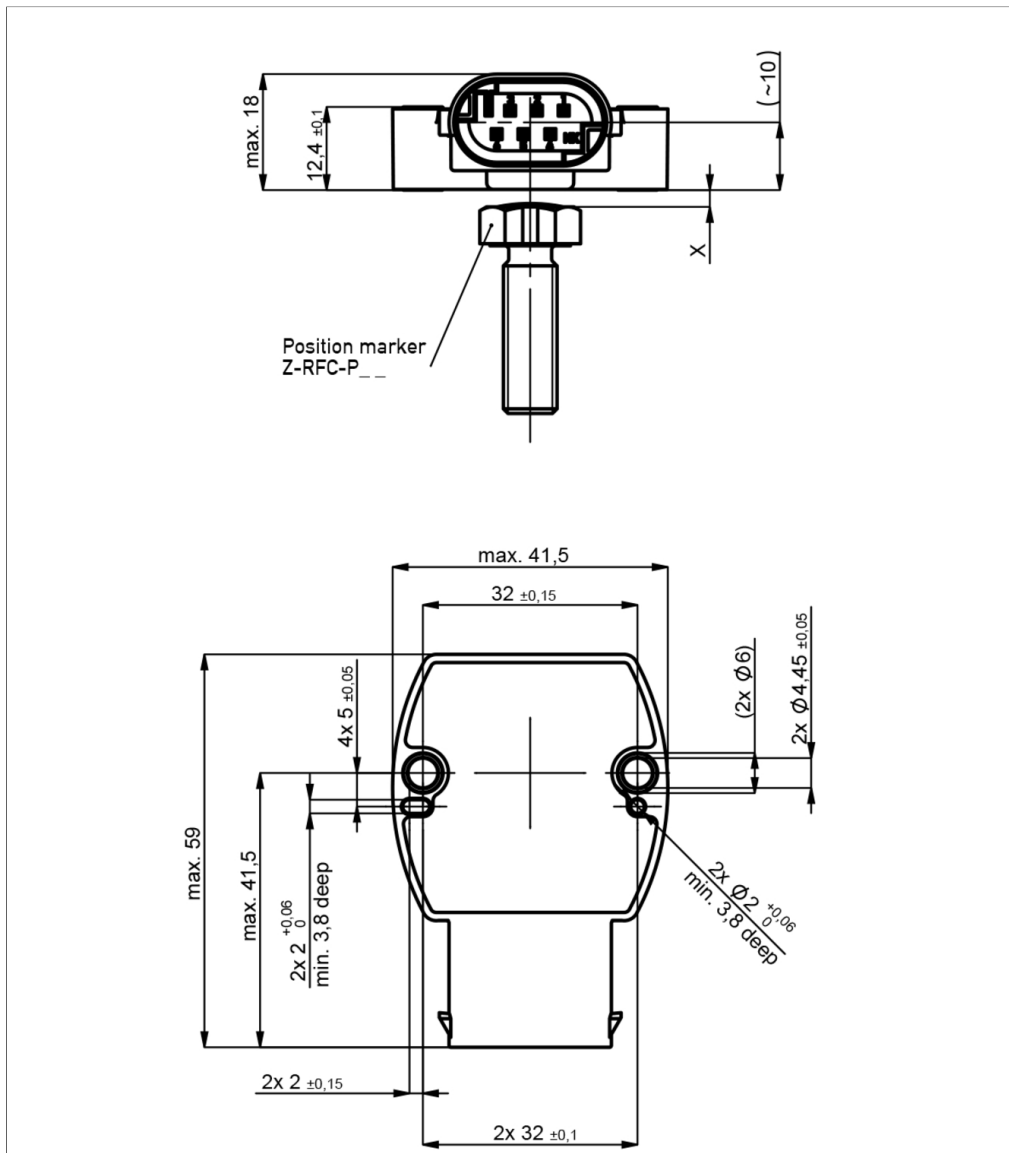

CAD data see
www.novotechnik.de/en/download/cad-data/

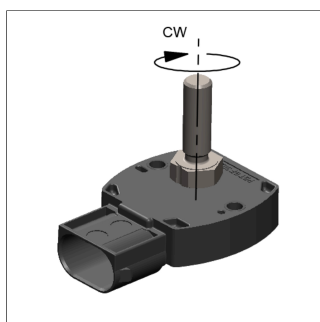

When the marking of the position marker points towards the connector, the sensor is near the electrical center position (index position).

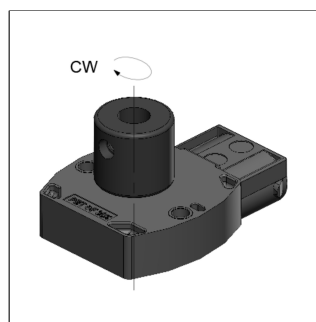

Only Z-RFC-P23/43:
When the marking of the position marker is pointing away from the connector, the sensor is near the electrical center position (index position).

Technical Data

Type	RFE-32_...-2_...-521 Ratiometric
Output signal	ratiometric to supply voltage U_b 5 ... 95% (0.25 ... 4.75 V) 10 ... 90% (0.5 ... 4.5 V)
Load	$\geq 5 \text{ k}\Omega$
Number of channels	1 / 2
Diagnosis	activated (in case of error, output signal is outside of the plausible signal range)
Update rate	typ. 3.4 kHz
Measuring range	0 ... 30° up to 0 ... 360° in 10°-steps
Independent linearity	$\leq \pm 0.5 \text{ \%FS}$
Resolution	12 bits
Repeatability	typ. $\leq \pm 0.1^\circ$
Hysteresis	typ. $< \pm 0.1^\circ$ Only measuring range 360°: typ. $< 0.25^\circ$ (lower hysteresis on request)
Temperature error	Measuring range 30 ... 170°: typ. $\pm 0.7 \text{ \%FS}$, Measuring range $\geq 180^\circ$: typ. $\pm 0.35 \text{ \%FS}$
Supply voltage U_b	5 VDC (4.5 ... 5.5 VDC)
Current consumption w/o load	typ. 12 mA per channel
Overvoltage protection	24 VDC (60 min.)
Polarity protection	yes (supply lines and outputs)
Short circuit protection	yes (vs. GND and supply voltage)
Insulation resistance (500 VDC)	$\geq 10 \text{ M}\Omega$
Environmental Data	
Max. operational speed	Mechanically unlimited
Vibration IEC 60068-2-6	20 g, 5 ... 2000 Hz, $A_{max} = 0.75 \text{ mm}$
Shock IEC 60068-2-27	50 g, 6 ms
Protection class ISO 20653	IP67 / IP68 / IP69K
Operating temperature	-40 ... +125°C
Life	Mechanically unlimited
Functional safety	Suitable for safety-related applications according to ISO 13849 after customer validation. Further safety data (DCavg...) and support for functional safety are available on request.
MTTF (IEC 60050)	1652 years (one-channel), 824 years (partly redundant, per channel) or 826 years (fully redundant, per channel)
MTTFd (EN ISO 13849-1 parts count method, w/o load)	3304 years (one-channel), 1648 years (partly redundant, per channel) or 1653 years (fully redundant, per channel)
MTTFd Declaration of Conformity	https://www.novotechnik.de/en/downloads/certificates/mttfd-certificate
Traceability	Serial number on type labeling; production batch of the sensor assembly and relevant sensor components
Conformity/Approval	CE, UKCA, E1 see https://www.novotechnik.de/en/downloads/certificates/declarations-of-conformity-eu/uk WEEE see https://www.novotechnik.de/en/downloads/certificates/eu-directive-weee/
EMC Compatibility	
ISO 10605 ESD (Handling/Component)	8 kV / 15 kV
ISO 11452-2 Radiated HF-fields	100 V/m
ISO 11452-5 Radiated HF-Fields, stripline	200 V/m
CISPR 25 Radiated emission	Level 5
EN 13309 Construction machinery	
Emission/Immunity E1	acc. to ECE-R10
ISO 13766-1/-2 Construction machinery	On request

FS = Full scale: Signal span according to electrical measuring range

Connection Assignment

	Single-channel	Partly redundant	Fully redundant
Supply voltage Ub 1	Pin 1	Pin 1 / Pin 6	Pin 1
GND 1	Pin 2	Pin 2 / Pin 5	Pin 2
Signal output 1	Pin 4	Pin 4	Pin 4
Signal output 2	-	Pin 3	Pin 3
Supply voltage Ub 2	-	-	Pin 6
GND 2	-	-	Pin 5
Not assigned	Pin 3, Pin 5, Pin 6	-	-

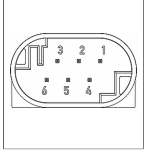

**Technical Data
Output
Characteristics**

Output characteristic

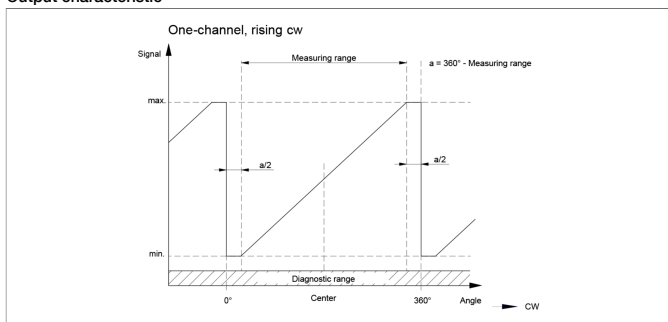

Output characteristic

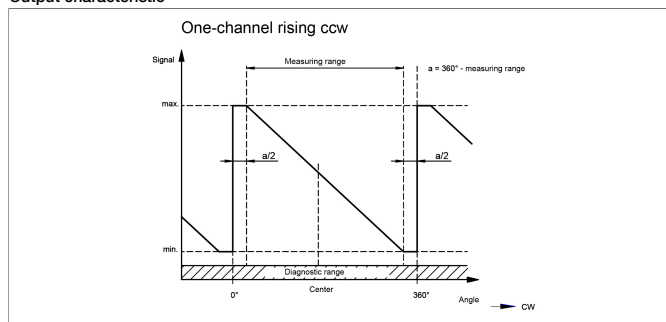

Output characteristic

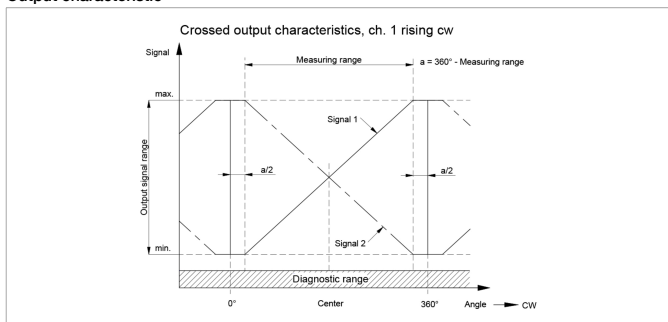

Output characteristic

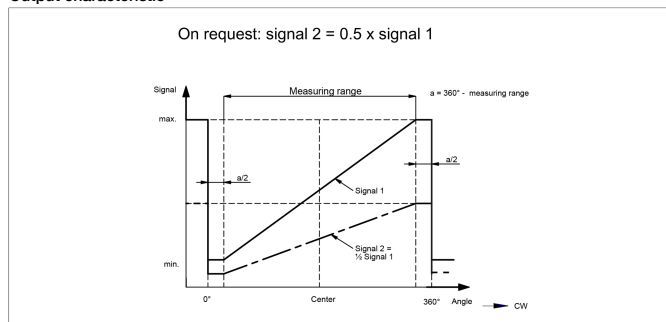

Output characteristic

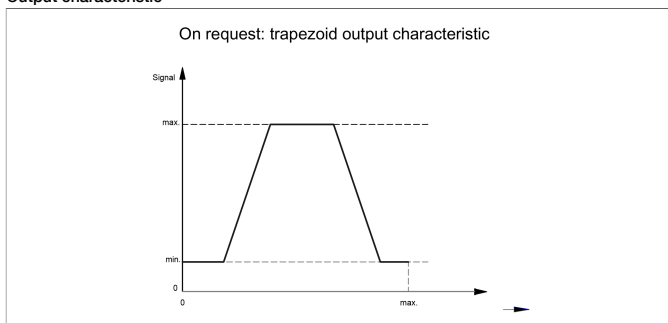

Output characteristic

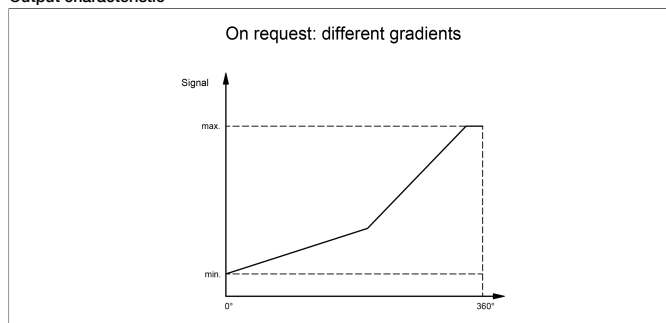

Output characteristic

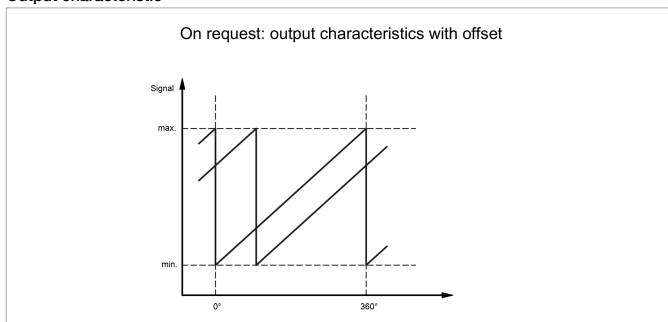

Output characteristic

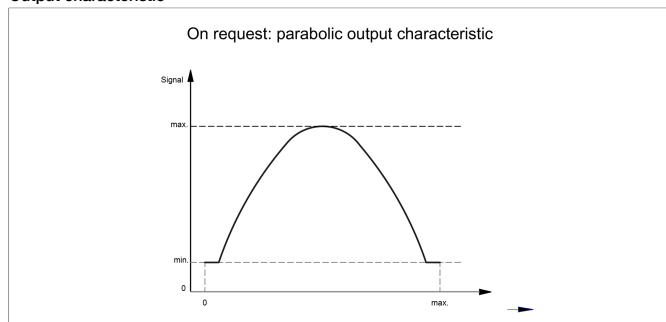

Position Markers

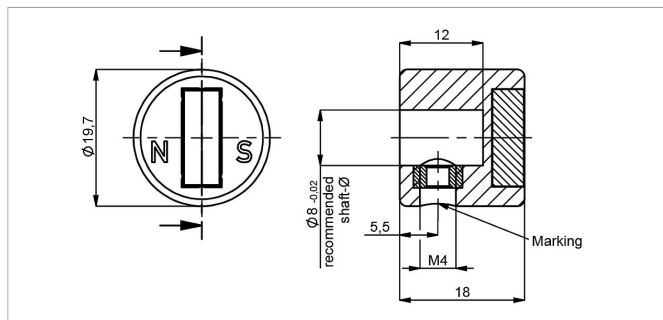

Z-RFC-P23

Position marker for fixation with threaded pin M4 (included in delivery)

Caution: For orientation of the output characteristic please follow the user manual of the position marker!

Material PA6-GF

Max. permitted ± 3 mm

radial offset

Operating temp. $-40 \dots +125^{\circ}\text{C}$

P/N	Pack. unit [pcs]
400056074	1
400056085	25

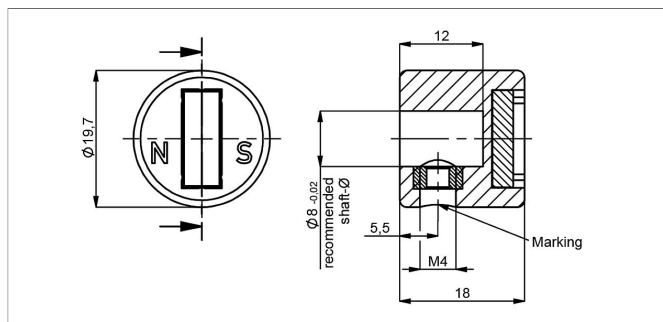

Z-RFC-P43

Position marker for fixation with threaded pin M4 (included in delivery)

Caution: For orientation of the output characteristic please follow the user manual of the position marker!

Material PA6-GF

Max. permitted ± 3 mm

radial offset

Operating temp. $-40 \dots +125^{\circ}\text{C}$

P/N	Pack. unit [pcs]
400105041	1
400105042	25

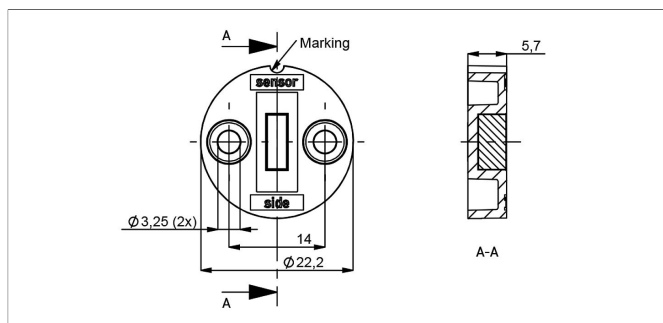

Z-RFC-P30

Position marker for frontal fixation with 2 cylinder screws M3x8 (included in delivery).

Material PBT-GF

Max. permitted ± 1.5 mm

radial offset

Operating temp. $-40 \dots +125^{\circ}\text{C}$

P/N	Pack. unit [pcs]
400056086	1
400056087	25

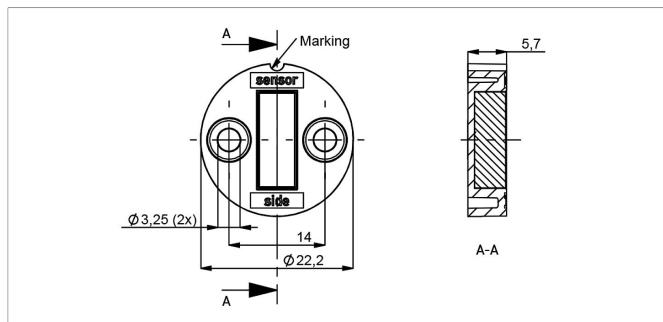

Z-RFC-P31

Position marker for frontal fixation with 2 cylinder screws M3x8 (included in delivery).

Material PBT-GF

Max. permitted ± 3 mm

radial offset

Operating temp. $-40 \dots +125^{\circ}\text{C}$

P/N	Pack. unit [pcs]
400056088	1
400056089	25

Position Markers

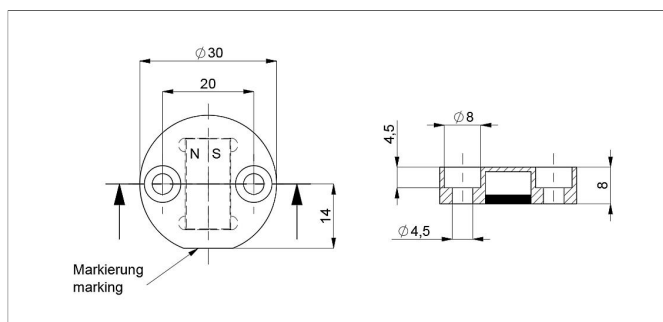
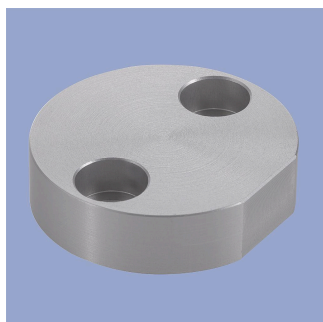

Z-RFC-P22

Position marker for frontal fixation with 2 cylinder head screws M4x20 (with screw lock, included in delivery).

Attention: Closed side of position marker faces the active side of sensor.

Material Aluminium, anodized
Max. permitted radial offset ± 4 mm
Operating temp. $-40 \dots +125^\circ\text{C}$

P/N	Pack. unit [pcs]
400106735	1
400106736	25

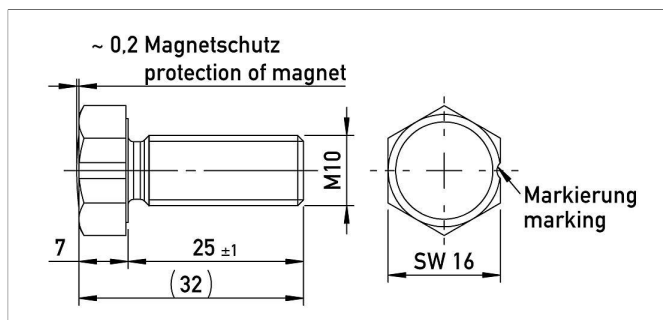

Z-RFC-P18

Screw position marker M10 x 25 mm, similar DIN 933, magnet potted

Material Aluminium, anodized
Max. permitted radial offset ± 3 mm
Operating temp. $-40 \dots +125^\circ\text{C}$

P/N	Pack. unit [pcs]
400104756	1
400104757	25

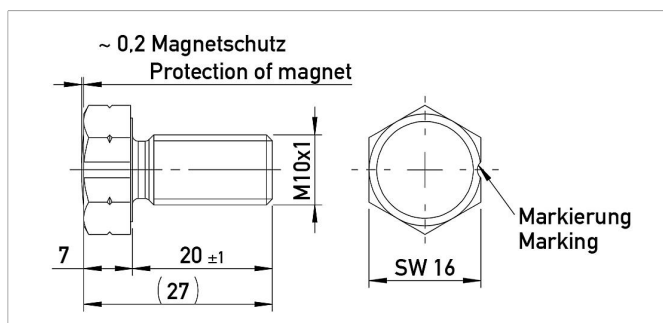

Z-RFC-P28

Screw position marker M10x1 x 20 mm, similar DIN 933, magnet potted

Material Aluminium, anodized
Max. permitted radial offset ± 3 mm
Operating temp. $-40 \dots +125^\circ\text{C}$

P/N	Pack. unit [pcs]
400108462	1
400108463	25

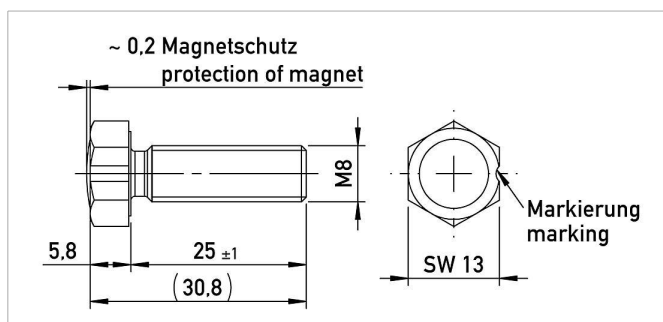

Z-RFC-P19

Screw position marker M8 x 25 mm, similar DIN 933/ISO 4017, magnet potted

Material Aluminium, anodized
Max. permitted radial offset ± 1.5 mm
Operating temp. $-40 \dots +125^\circ\text{C}$

P/N	Pack. unit [pcs]
400104754	1
400104755	25

Position Markers

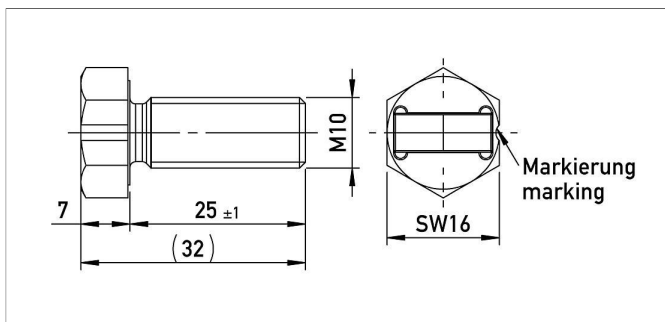

Z-RFC-P20

Screw position marker M10 x 25 mm, similar DIN 933

Material Aluminium, anodized

Max. permitted radial offset ± 3 mm

radial offset

Operating temp. -40 ... +125°C

P/N	Pack. unit [pcs]
400104758	1
400104759	25

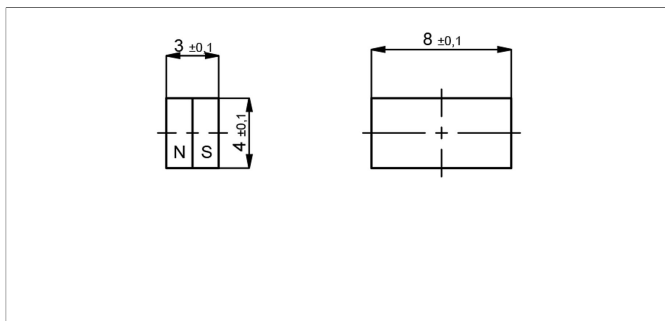

Z-RFC-P03

Magnet for direct application onto customer's shaft (see user manual).

We recommend mounting on non-magnetizable materials, otherwise the specified working distances will vary (e.g. reduction of approx. 20% with axial mounting on a magnetizable shaft).

Max. permitted radial offset ± 1.5 mm

radial offset

Operating temp. -40 ... +125°C

P/N	Pack. unit [pcs]
400005658	1
400056081	50

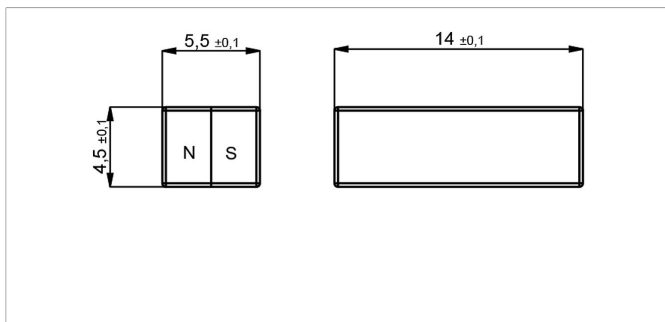

Z-RFC-P04

Magnet for direct application onto customer's shaft (see user manual).

We recommend mounting on non-magnetizable materials, otherwise the specified working distances will vary (e.g. reduction of approx. 20% with axial mounting on a magnetizable shaft).

Max. permitted radial offset ± 3 mm

radial offset

Operating temp. -40 ... +125°C

P/N	Pack. unit [pcs]
400005659	1
400056082	50

Position Markers

Working Distances Position Markers [mm] - Single-channel Versions

Z-RFC-P03	Z-RFC-P04	Z-RFC-P18 / P28	Z-RFC-P19	Z-RFC-P20	Z-RFC-P22	Z-RFC-P23	Z-RFC-P30	Z-RFC-P31	Z-RFC-P43
0.4 ... 1.9	2 ... 4.7	0 ... 4	0 ... 1.8	2 ... 4.7	4.1 ... 8.9	2 ... 4.7	0.4 ... 1.9	2 ... 4.7	0 ... 2.4

Working Distances Position Markers [mm] - Redundant Versions

Z-RFC-P03	Z-RFC-P04	Z-RFC-P18 / P28	Z-RFC-P19	Z-RFC-P20	Z-RFC-P22	Z-RFC-P23	Z-RFC-P30	Z-RFC-P31	Z-RFC-P43
0 ... 1.5	1.6 ... 4.2	0 ... 3.5	0 ... 1.3	1.6 ... 4.2	3.6 ... 8.4	1.6 ... 4.2	0 ... 1.5	1.6 ... 4.2	0 ... 2

Lateral Magnet Offset

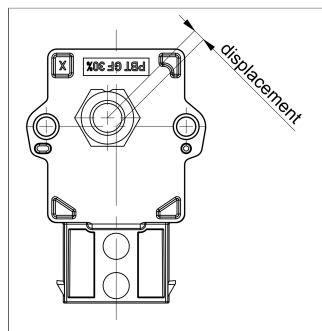

Lateral magnet offset will cause additional linearity error. The angle error, which is caused by radial displacement of sensor and position marker depends on the used position marker or magnet.

Additional Linearity Error at Radial Displacement - Single-channel Versions

Z-RFC-P02 / P04 / P08	Z-RFC-P41 / P43 / P47	Z-RFC-P03 / P30	Z-RFC-P18 / P28	Z-RFC-P19	Z-RFC-P22
0.5 mm: $\pm 0.4^\circ$	0.5 mm: $\pm 0.4^\circ$	0.5 mm: $\pm 1.4^\circ$	0.5 mm: $\pm 0.7^\circ$	0.5 mm: $\pm 1.3^\circ$	1.0 mm: $\pm 0.8^\circ$
1.0 mm: $\pm 1.1^\circ$	1.0 mm: $\pm 1.1^\circ$	1.0 mm: $\pm 3.7^\circ$	1.0 mm: $\pm 1.3^\circ$	1.0 mm: $\pm 2.6^\circ$	2.0 mm: $\pm 1.8^\circ$
2.0 mm: $\pm 3.5^\circ$	2.0 mm: $\pm 3.5^\circ$	2.0 mm: -	2.0 mm: $\pm 3.3^\circ$	2.0 mm: -	4.0 mm: $\pm 5.4^\circ$

Additional Linearity Error at Radial Displacement - Redundant Versions

Z-RFC-P02 / P04 / P08	Z-RFC-P41 / P43 / P47	Z-RFC-P03 / P30	Z-RFC-P18 / P28	Z-RFC-P19	Z-RFC-P22
0.5 mm: $\pm 0.7^\circ$	0.5 mm: $\pm 0.7^\circ$	0.5 mm: $\pm 2.5^\circ$	0.5 mm: $\pm 1.1^\circ$	0.5 mm: $\pm 2.3^\circ$	1.0 mm: $\pm 1.1^\circ$
1.0 mm: $\pm 1.8^\circ$	1.0 mm: $\pm 1.8^\circ$	1.0 mm: $\pm 6.4^\circ$	1.0 mm: $\pm 2^\circ$	1.0 mm: $\pm 4.5^\circ$	2.0 mm: $\pm 2.4^\circ$
2.0 mm: $\pm 5.2^\circ$	2.0 mm: $\pm 5.2^\circ$	2.0 mm: -	2.0 mm: $\pm 4.6^\circ$	2.0 mm: -	4.0 mm: $\pm 6.7^\circ$

Connector System MQS

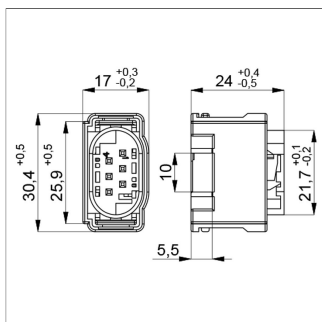

EEM-33-34

Connector kit MQS System including

- 1 plug socket (female), PBT GF15, AMP P/N 1-967616-1
- 6 tinned contacts for cable cross-section area 0.25 ... 0.35 mm² (AWG 22), AMP-P/N 963727-1 or 5-962885-1
- 6 single conductor sealings AMP P/N 967067-2

Operating temp. -40 ... +120°C

P/N	Type
400005666	EEM-33-34

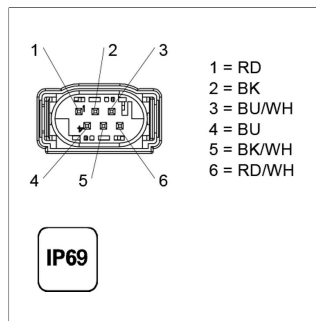
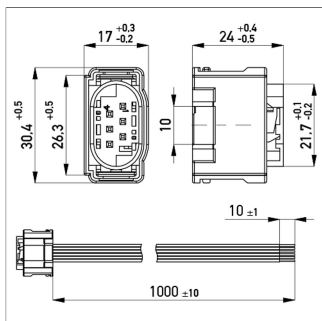
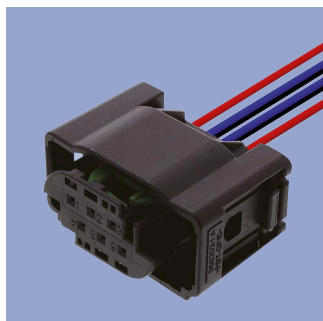

EEM-33-24

Connector MQS AMP P/N 1-967616-1, 6-pin, PBT GF15, with lead wires 0.5 mm², PVC, 1 m, open ended

Operating temp. -40 ... +120°C

Lead wires PVC, 6x0.5 mm²

P/N	Type	Length
400108029	EEM-33-24	1 m

Novotechnik U.S., Inc.
155 Northboro Road

Southborough, MA 01772
Phone 508 485 2244
Fax 508 485 2430
info@novotechnik.com
www.novotechnik.com



© Apr 10, 2026

The specifications contained in our datasheets are intended solely for informational purposes. The documented specification values are based on ideal operational and environmental conditions and can vary significantly depending on the actual customer application. Using our products at or close to one or more of the specified performance ranges can lead to limitations regarding other performance parameters. It is therefore necessary that the end user verifies relevant performance parameters in the intended application. We reserve the right to change product specifications without notice.