

**NOVOHALL
Rotary Sensor
Touchless**

**RFC-4800
CAN SAE J1939
Mobile Applications**

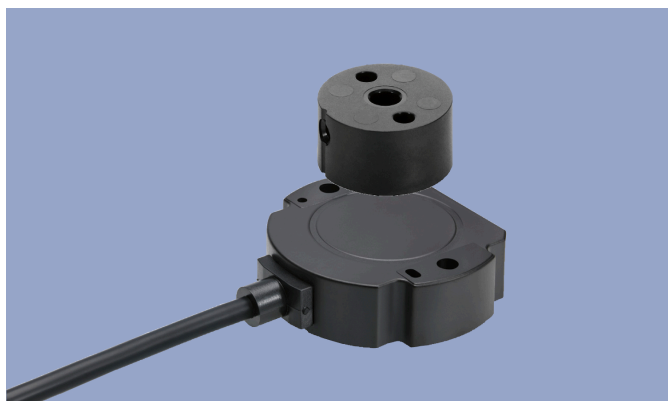

Special Features

- Touchless hall technology
- Electrical range 360°
- 2 part design, mechanically decoupled
- High protection class IP67, IP68, IP69
- Resolution 14 bit
- Wear-free
- Temperature range -40 °C to +105 °C
- One and multi-channel versions
- Optimized for use in mobile applications with highest EMC requirements such as ISO pulses and high interferences to ISO 11452, exceeds E1 requirements
- Other configurations see separate data sheets

Applications

- Mobile working machines (industrial trucks, construction machinery, agricultural and forestry machinery)
- Marine applications

The 2 part design consisting of sensor and magnetic position marker offers great flexibility when mounting. The absence of shaft and bearing makes the assembly much less sensitive to axial and radial application tolerances - separate couplings are obsolete. Measurements can be made transmissively through any non-ferromagnetic material.

The sensor is perfectly suitable for use in harsh environmental conditions through the completely encapsulated electronics.

Description

Material	Housing: high grade, temperature resistant plastic
Mounting	With 2 pan head screws M4x20 (included in delivery)
Fastening torque of mounting	250 Ncm
Electrical connection	Cable 2x 2x 0.34 mm ² (AWG 22), TPE, shielded / Connector M12x1, A-coded with cable L = 0.15 m / Cable 4x 2x 0.25 mm ² (AWG 24), TPE, shielded

Mechanical Data

Dimensions	See dimension drawing
Mechanical travel	continuous
Weight (w/o connection)	approx. 50 g

Ordering Specifications

Ordering Specifications

Preferred types printed in bold

- Delivery time up to 25 pcs. within 10 working days EXW
- Best low-volume pricing

Interface

J: CAN SAE J1939

Interface parameters

Single-channel version

1: 1x position, 1x speed, 1x revolution counter

5: 1x position, 1x speed, 1x revolution counter with bus termination 120 Ω

Dual-channel version

2: 2x position, 2x speed

3: 2x position, 1x revolution counter

6: 2x position, 2x speed with bus termination 120 Ω

7: 2x position, 1x revolution counter with bus termination 120 Ω

Baud rate

3: 500 kBaud

4: 250 kBaud

Electrical connection

231: Cable, 4-pole, shielded, L = 0.5 m

232: Cable, 4-pole, shielded, L = 1 m

236: Cable, 4-pole, shielded, L = 3 m

240: Cable, 4-pole, shielded, L = 5 m

432: Cable, 8-pole, shielded, L = 1 m (CAN in/out)*

511: Connector M12x1, 5-pin, with cable, shielded, L = 0.15 m

Cable versions and assembled connectors on request

*) Only models without bus termination 120 Ω

R F C - 4 8 5 2 - 2 1 4 - J 1 4 - 2 3 2

Series

Mechanical version

4851: Elongated hole mounting

4852: Round hole mounting

Resolution
14: 14 bits

Interface
2: Digital Interface

Accessories included in delivery

- 2x Pan head screws M4x20

Drawing

CAD data see
www.novotechnik.de/en/download/cad-data/

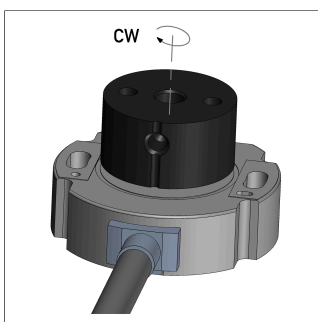
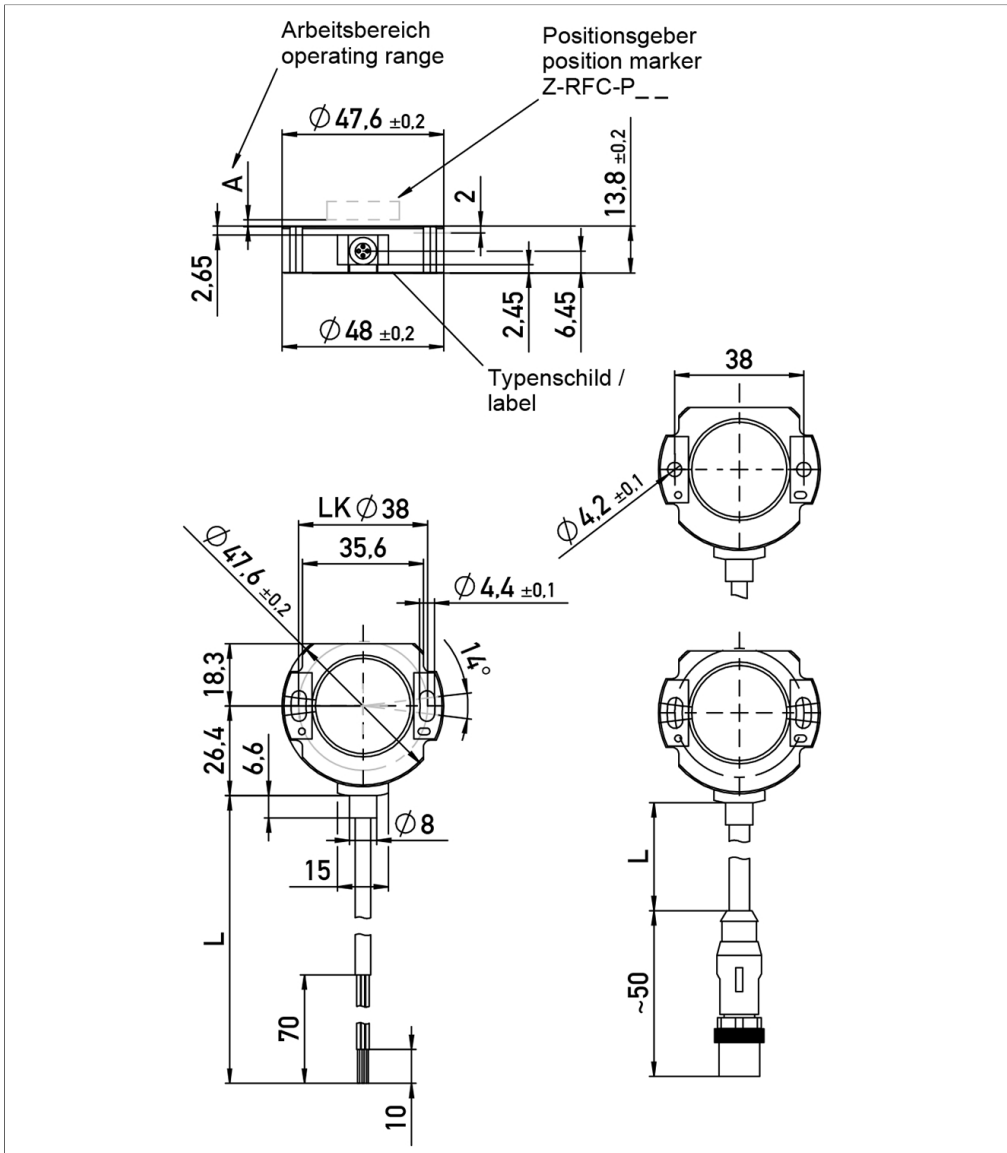

When the marking of the position marker is pointing towards the cable, the sensor output is near the electrical center position (index position).

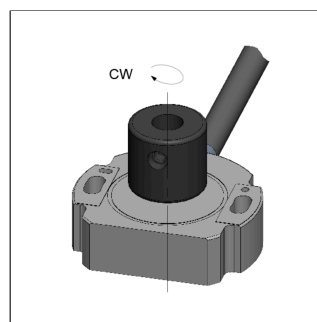

Only Z-RFC-P23/P43:
When the marking of the position marker is pointing away from the cable, the sensor output is near the electrical center position (index position).

Technical Data

Type	RFC-48_-214-J_-_-_-_- CAN SAE J1939
Measured variables	Position, speed, revolution counter
Measuring range	360°
Measuring range speed	0 ... 750 rpm
Number of channels	1 / 2
Output signal / Protocol	CAN SAE J1939
Programmable parameters	Offset position, counting direction, averaging, baud rate, transmit mode, transmit cycle, source address, resolution position, resolution speed
Diagnosis	activated (in case of error, output signal is outside of the plausible signal range)
Source Address	128 ... 247 (dynamic address claiming)
Baud rate	250, 500 kBAud
Update rate (output)	1 kHz
Resolution position (across 360°)	14 bits
Resolution speed (LSB)	0.055°/s ... 2.2°/s
Independent linearity	≤ ±0.5 %FS
Repeatability	≤ ±0.1°
Hysteresis	≤ ±0.1°
Temperature error	±0.2 %FS
Supply voltage U _b	12/24 VDC (8 ... 34 VDC)
Current consumption at Power-on	≤ 50 mA
Power drain w/o load	< 0.4 W
Overvoltage protection	45 VDC (permanent)
Polarity protection	yes (supply lines)
Short circuit protection	yes (all outputs vs. GND and supply voltage up to 40 VDC)
Insulation resistance (500 VDC)	≥ 10 MΩ
Bus termination internal	120 Ω (optionally)
Environmental Data	
Max. operational speed	Mechanically unlimited
Vibration IEC 60068-2-6	20 g, 5 ... 2000 Hz, A _{max} = 0.75 mm
Shock IEC 60068-2-27	50 g, 6 ms
Protection class DIN EN 60529	IP67 / IP68 / IP69, IP67 (connector M12)
Operating temperature	-40 ... +105°C, -25 ... +85°C (connector M12)
Life	Mechanically unlimited
Functional safety	If you need assistance in using our products in safety-related systems, please contact us
MTTF (IEC 60050)	843 years (one-channel) or 819 years (two-channel, per channel)
Traceability	Serial number on type labeling: production batch of the sensor assembly and relevant sensor components
Conformity/Approval	CE, UKCA see https://www.novotechnik.de/en/downloads/certificates/declarations-of-conformity-eu/uk WEEE see https://www.novotechnik.de/en/downloads/certificates/eu-directive-weee/
EMC Compatibility	
ISO 10605 ESD (Handling/Component)	8 kV
ISO 11452-2 Radiated HF-fields	100 V/m
ISO 11452-4 BCI (Bulk current injection)	200 mA
CISPR 25 Radiated emission	Level 3
ISO 7637-2 Transient Emissions	Level 4
ISO 7637-2 Pulses on supply lines	(1, 2a, 2b, 3a, 3b, 4, 5) Level 4
ISO 7637-3 Pulses on output lines	(3a, 3b) Fast Level 2, Slow Level 4
Emission/Immunity	Exceeds E1 requirements

FS = Full scale: Signal span according to electrical measuring range

Connection Assignment

Signal	Cable code 2__	Connector code 5__	Cable code 4__
Supply voltage Ub	WH	Pin 2	WH, RD
GND	BN	Pin 3	BN, BU
CAN_H	YE	Pin 4	YE, PK
CAN_L	GN	Pin 5	GN, GY
CAN_SHLD	Shield	Pin 1	Shield
Connect cable shielding to GND			

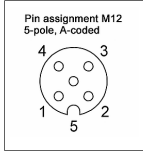

Position Markers

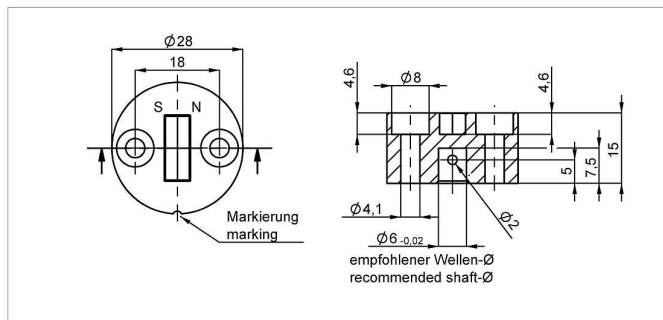

Z-RFC-P02

Position marker for frontal fixation with 2 cylinder head screws M4x20 (with screw lock) or with locking pin (both included in delivery).

Material PF
Max. permitted ± 3 mm
radial offset
Operating temp. $-40 \dots +125^\circ\text{C}$

P/N	Pack. unit [pcs]
40005661	1
400056080	25

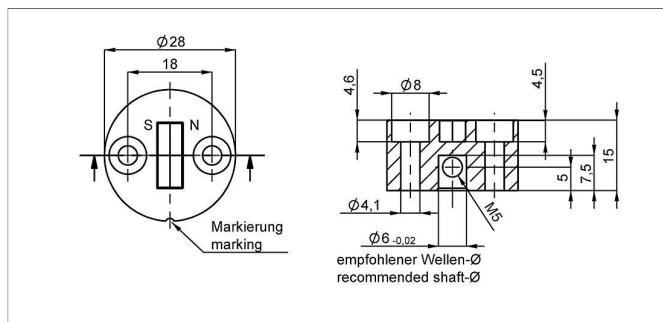
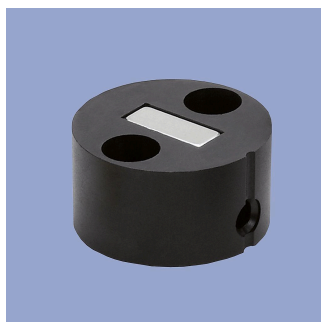

Z-RFC-P08

Position marker for fixation with threaded pin M5 (included in delivery).

Material PF
Max. permitted ± 3 mm
radial offset
Operating temp. $-40 \dots +125^\circ\text{C}$

P/N	Pack. unit [pcs]
400056070	1
400056084	25

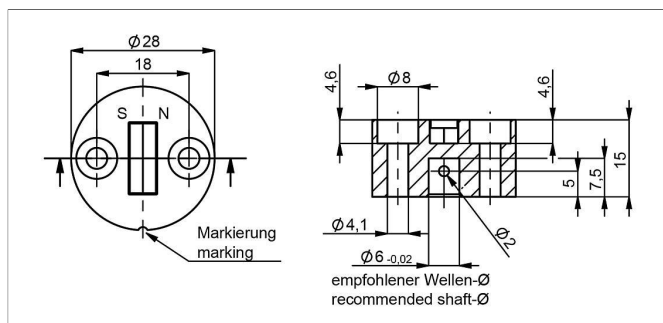

Z-RFC-P41

Position marker for frontal fixation with 2 cylinder head screws M4x20 (with screw lock) or with locking pin (both included in delivery).

Material PF
Max. permitted ± 3 mm
radial offset
Operating temp. $-40 \dots +125^\circ\text{C}$

P/N	Pack. unit [pcs]
400105037	1
400105038	25

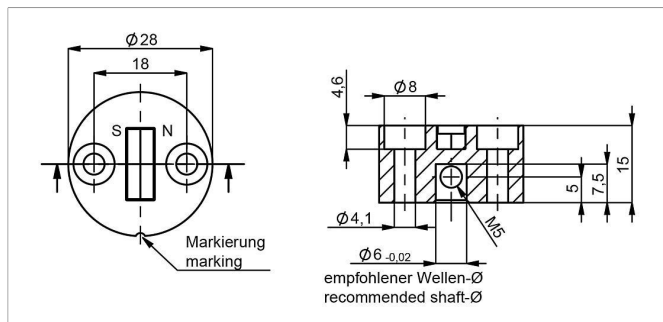

Z-RFC-P47

Position marker for frontal fixation with 2 cylinder head screws M4x20 (with screw lock) or with threaded pin M5 (both included in delivery).

Material PF
Max. permitted ± 3 mm
radial offset
Operating temp. $-40 \dots +125^\circ\text{C}$

P/N	Pack. unit [pcs]
400105039	1
400105040	25

Position Markers

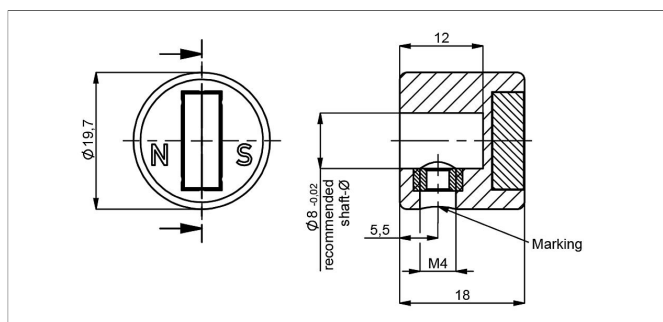

Z-RFC-P23

Position marker for fixation with threaded pin M4 (included in delivery)

Caution: For orientation of the output characteristic please follow the user manual of the position marker!

Material PA6-GF

Max. permitted ± 3 mm

radial offset

Operating temp. $-40 \dots +125^\circ\text{C}$

P/N	Pack. unit [pcs]
400056074	1
400056085	25

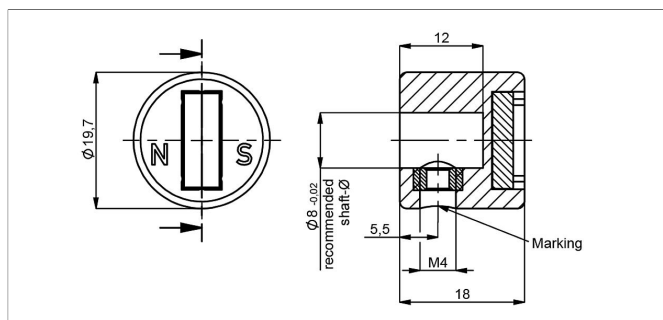

Z-RFC-P43

Position marker for fixation with threaded pin M4 (included in delivery)

Caution: For orientation of the output characteristic please follow the user manual of the position marker!

Material PA6-GF

Max. permitted ± 3 mm

radial offset

Operating temp. $-40 \dots +125^\circ\text{C}$

P/N	Pack. unit [pcs]
400105041	1
400105042	25

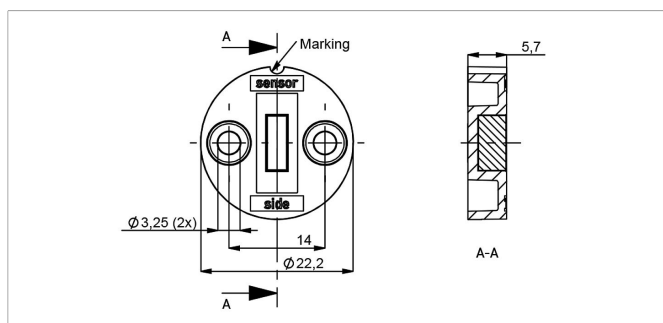

Z-RFC-P30

Position marker for frontal fixation with 2 cylinder screws M3x8 (included in delivery).

Material PBT-GF

Max. permitted ± 1.5 mm

radial offset

Operating temp. $-40 \dots +125^\circ\text{C}$

P/N	Pack. unit [pcs]
400056086	1
400056087	25

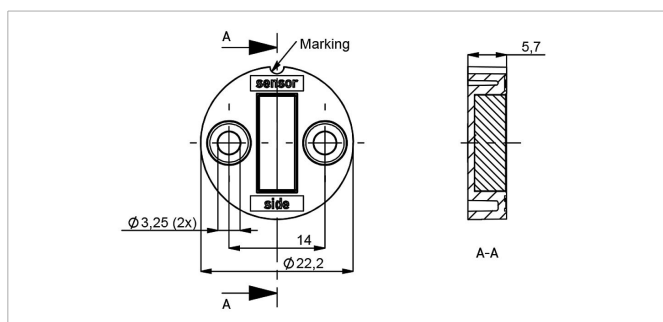

Z-RFC-P31

Position marker for frontal fixation with 2 cylinder screws M3x8 (included in delivery).

Material PBT-GF

Max. permitted ± 3 mm

radial offset

Operating temp. $-40 \dots +125^\circ\text{C}$

P/N	Pack. unit [pcs]
400056088	1
400056089	25

Position Markers

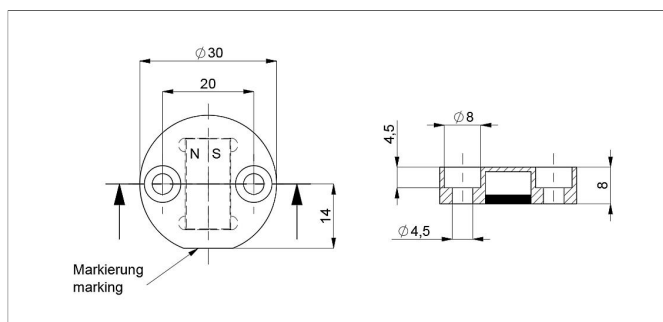
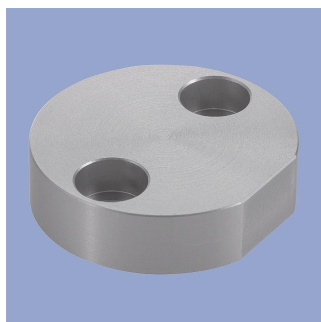

Z-RFC-P22

Position marker for frontal fixation with 2 cylinder head screws M4x20 (with screw lock, included in delivery).

Attention: Closed side of position marker faces the active side of sensor.

Material Aluminium, anodized
Max. permitted radial offset ± 4 mm
Operating temp. $-40 \dots +125^\circ\text{C}$

P/N	Pack. unit [pcs]
400106735	1
400106736	25

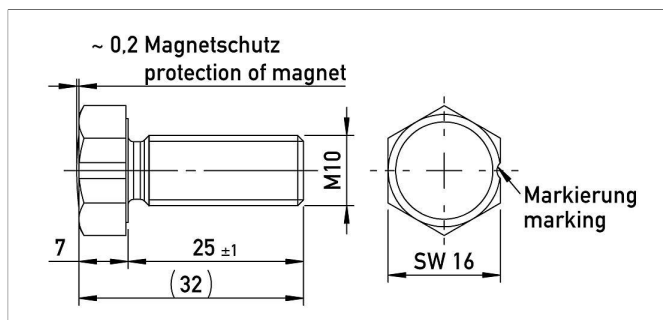

Z-RFC-P18

Screw position marker M10 x 25 mm, similar DIN 933, magnet potted

Material Aluminium, anodized
Max. permitted radial offset ± 3 mm
Operating temp. $-40 \dots +125^\circ\text{C}$

P/N	Pack. unit [pcs]
400104756	1
400104757	25

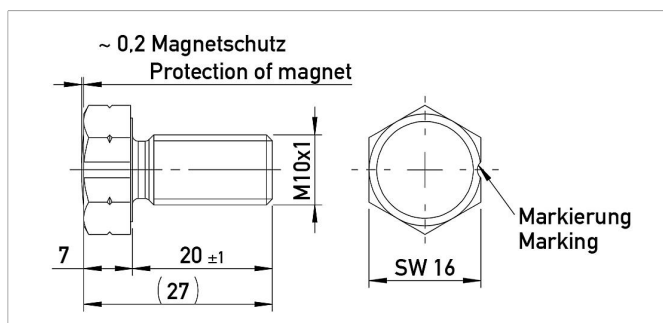

Z-RFC-P28

Screw position marker M10x1 x 20 mm, similar DIN 933, magnet potted

Material Aluminium, anodized
Max. permitted radial offset ± 3 mm
Operating temp. $-40 \dots +125^\circ\text{C}$

P/N	Pack. unit [pcs]
400108462	1
400108463	25

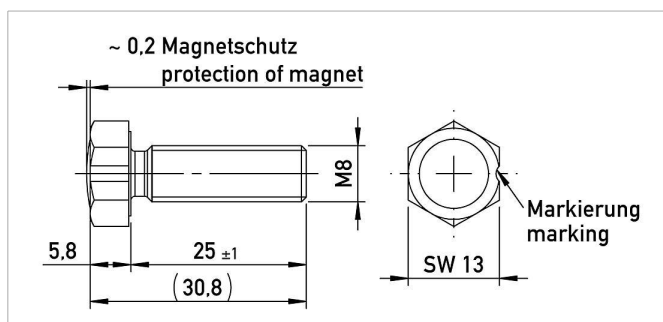

Z-RFC-P19

Screw position marker M8 x 25 mm, similar DIN 933/ISO 4017, magnet potted

Material Aluminium, anodized
Max. permitted radial offset ± 1.5 mm
Operating temp. $-40 \dots +125^\circ\text{C}$

P/N	Pack. unit [pcs]
400104754	1
400104755	25

Position Markers

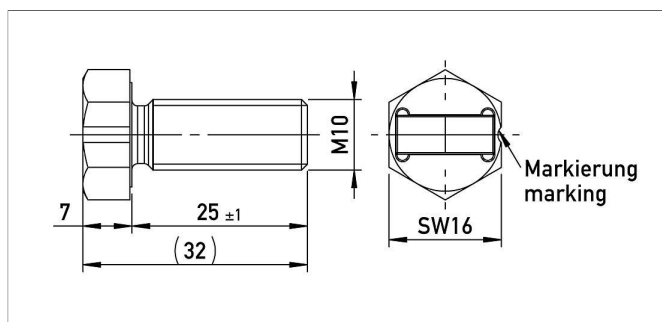

Z-RFC-P20

Screw position marker M10 x 25 mm, similar DIN 933

Material Aluminium, anodized

Max. permitted radial offset ± 3 mm

Operating temp. -40 ... +125°C

P/N

Pack. unit [pcs]

400104758	1
400104759	25

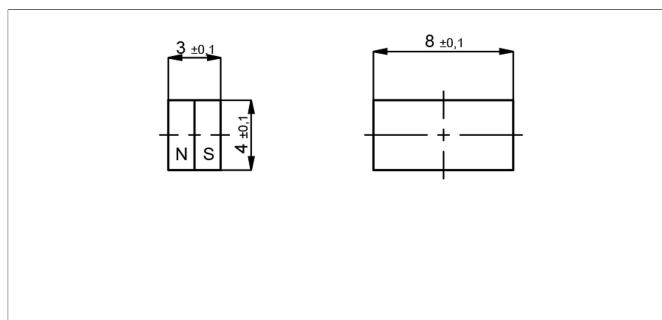

Z-RFC-P03

Magnet for direct application onto customer's shaft (see user manual).

We recommend mounting on non-magnetizable materials, otherwise the specified working distances will vary (e.g. reduction of approx. 20% with axial mounting on a magnetizable shaft).

Max. permitted radial offset ± 1.5 mm

Operating temp. -40 ... +125°C

P/N

Pack. unit [pcs]

400005658	1
400056081	50

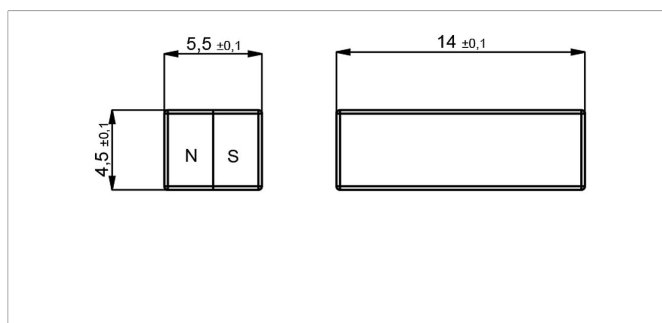

Z-RFC-P04

Magnet for direct application onto customer's shaft (see user manual).

We recommend mounting on non-magnetizable materials, otherwise the specified working distances will vary (e.g. reduction of approx. 20% with axial mounting on a magnetizable shaft).

Max. permitted radial offset ± 3 mm

Operating temp. -40 ... +125°C

P/N

Pack. unit [pcs]

400005659	1
400056082	50

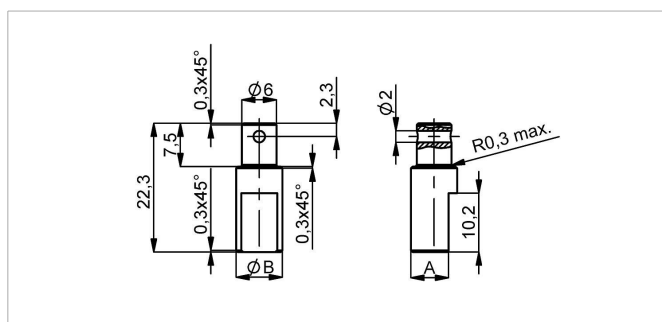
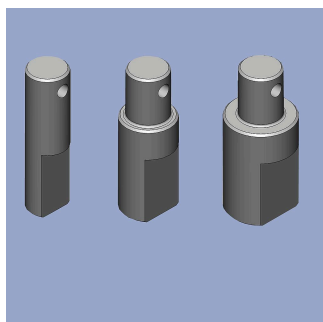

Z-RFC-S01/S02/S03

Shaft adapter for fixation at position marker Z-RFC-P02/P41 with locking pin

Material SS 1.4305 / AISI 303

P/N Type ØB / A [mm]

400056206 Z-RFC-S01 6 / 4.5

400056207 Z-RFC-S02 8 / 6.5

400056208 Z-RFC-S03 10 / 8.5

Position Markers

Working Distances Position Markers [mm] - Single-channel Versions

Z-RFC-P02 / P04 / P08 Z-RFC-P20 / P23 / P31	Z-RFC-P41 / P43 / P47	Z-RFC-P03 / P30	Z-RFC-P18 / P28	Z-RFC-P19	Z-RFC-P22
2.3 ... 5	0 ... 2.7	0.7 ... 2.2	0 ... 4.5	0 ... 2.2	4.4 ... 9.2

Working Distances Position Markers [mm] - Redundant Versions

Z-RFC-P02 / P04 / P08 Z-RFC-P20 / P23 / P31	Z-RFC-P41 / P43 / P47	Z-RFC-P03 / P30	Z-RFC-P18 / P28	Z-RFC-P19	Z-RFC-P22
1.9 ... 4.5	0 ... 2.3	0.3... 1.8	0 ... 4	0 ... 1.7	4 ... 8.8

Lateral Magnet Offset

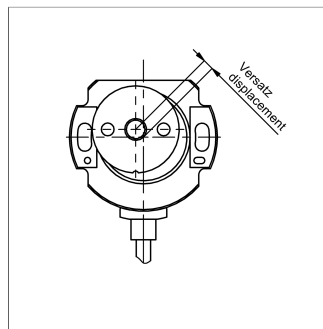

Lateral magnet offset will cause additional linearity error. The angle error, which is caused by radial displacement of sensor and position marker depends on the used position marker or magnet.

Additional Linearity Error at Radial Displacement - Single-channel Versions

Z-RFC-P02 / P04 / P08 Z-RFC-P20 / P23 / P31	Z-RFC-P41 / P43 / P47	Z-RFC-P03 / P30	Z-RFC-P18 / P28	Z-RFC-P19	Z-RFC-P22
0.5 mm: $\pm 0.4^\circ$	0.5 mm: $\pm 0.4^\circ$	0.5 mm: $\pm 1.4^\circ$	0.5 mm: $\pm 0.7^\circ$	0.5 mm: $\pm 1.3^\circ$	1.0 mm: $\pm 0.8^\circ$
1.0 mm: $\pm 1.1^\circ$	1.0 mm: $\pm 1.1^\circ$	1.0 mm: $\pm 3.7^\circ$	1.0 mm: $\pm 1.3^\circ$	1.0 mm: $\pm 2.6^\circ$	2.0 mm: $\pm 1.8^\circ$
2.0 mm: $\pm 3.5^\circ$	2.0 mm: $\pm 3.5^\circ$	2.0 mm: -	2.0 mm: $\pm 3.3^\circ$	2.0 mm: -	4.0 mm: $\pm 5.4^\circ$

Additional Linearity Error at Radial Displacement - Redundant Versions

Z-RFC-P02 / P04 / P08 Z-RFC-P20 / P23 / P31	Z-RFC-P41 / P43 / P47	Z-RFC-P03 / P30	Z-RFC-P18 / P28	Z-RFC-P19	Z-RFC-P22
0.5 mm: $\pm 0.7^\circ$	0.5 mm: $\pm 0.7^\circ$	0.5 mm: $\pm 2.5^\circ$	0.5 mm: $\pm 1.1^\circ$	0.5 mm: $\pm 2.3^\circ$	1.0 mm: $\pm 1.1^\circ$
1.0 mm: $\pm 1.8^\circ$	1.0 mm: $\pm 1.8^\circ$	1.0 mm: $\pm 6.4^\circ$	1.0 mm: $\pm 2^\circ$	1.0 mm: $\pm 4.5^\circ$	2.0 mm: $\pm 2.4^\circ$
2.0 mm: $\pm 5.2^\circ$	2.0 mm: $\pm 5.2^\circ$	2.0 mm: -	2.0 mm: $\pm 4.6^\circ$	2.0 mm: -	4.0 mm: $\pm 6.7^\circ$

Connector System M12

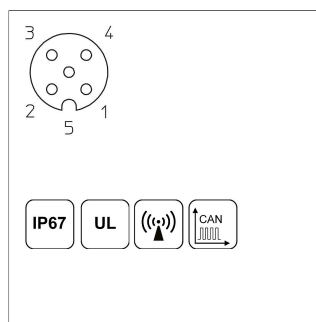
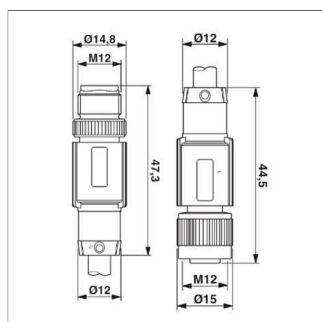

EEM-33-52
M12x1 Mating female/male connector, 5-pin, straight, A-coded, with molded cable, IP67, shielded (shield on knurl), CAN-Bus

Plug housing PUR
Cable sheath PUR, $\varnothing = 6.7$ mm, -25 ... +90°C (plug/socket)
-20 ... +80°C (cable)

Lead wires PE, 2x0.25 mm²+2x0.34 mm²

P/N	Type	Length
400106373	EEM-33-52	5 m

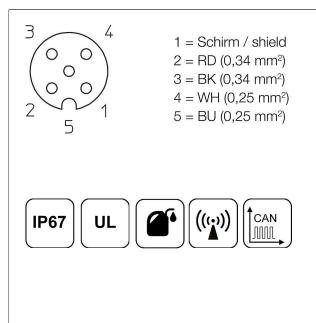
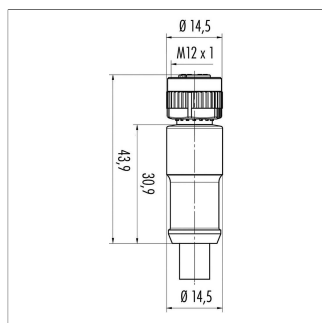

EEM-33-41/43
M12x1 Mating female connector, 5-pin, straight, A-coded, with molded cable, IP67, shielded, open ended, CAN-Bus

Plug housing PUR
Cable sheath PUR, $\varnothing = 7.2$ mm, -25 ... +85°C (fixed)

Lead wires PP, 2x0.25 mm²+2x0.34 mm²

P/N	Type	Length
400056141	EEM-33-41	2 m
400056143	EEM-33-43	10 m

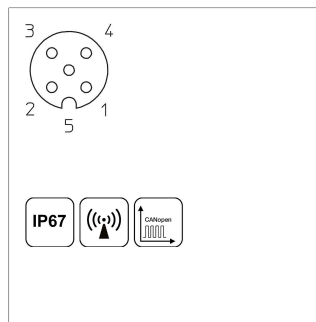
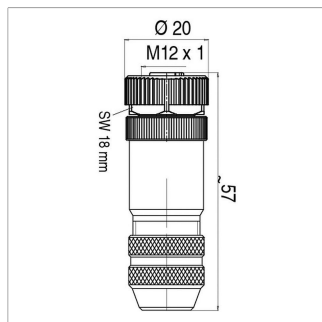

EEM-33-73
M12x1 Mating female connector, 5-pin, straight, A-coded, with coupling nut, screw termination, IP67, shieldable, CAN bus

Plug housing Metal, -40 ... +85°C
For wire gauge 6 ... 8 mm, max. 0.75 mm²

P/N	Type
400005645	EEM-33-73

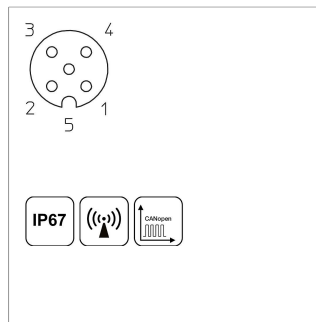
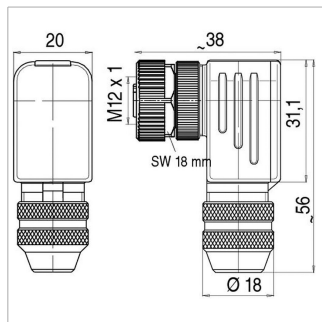

EEM-33-75
M12x1 mating female connector, 5-pin, angled, A-coded, with coupling nut, screw termination, IP67, shieldable, CAN bus, turning and fixing of contact carrier in 90° positions possible.

Plug housing Metal, -40 ... +85°C
For wire gauge 6 ... 8 mm, max. 0.75 mm²

P/N	Type
400005646	EEM-33-75

Connector System M12

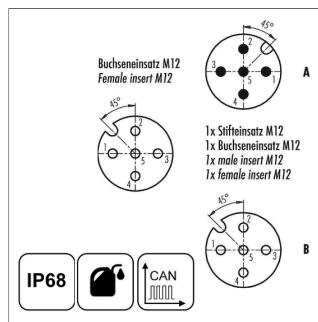
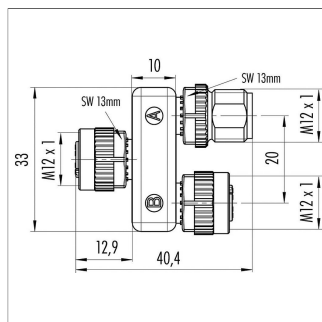

EEM-33-45
M12x1 splitter / T-connector, 5-pin,
A-coded, IP68, 1:1 connection,
female - male - female, CAN-Bus
Plug housing PUR, -25 ... +85°C
P/N **Type**
400056145 EEM-33-45

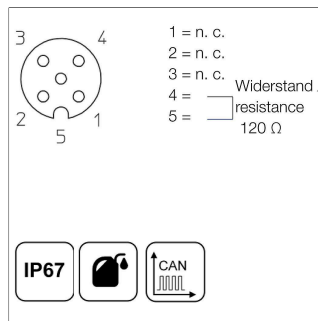
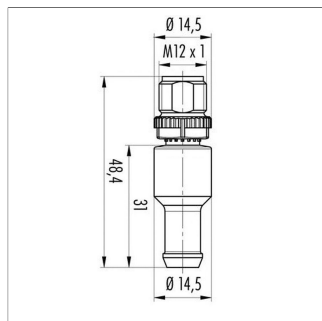

EEM-33-47
M12x1 terminating resistor, 5-pin, A-coded,
IP67, 120 Ω resistance, CAN-Bus
Plug housing PUR, -25 ... +85°C
P/N **Type**
400056147 EEM-33-47

IP67 Protection class IP67 DIN EN 60529

IP68 Protection class IP68 DIN EN 60529

 Very good Electromagnetic Compatibility (EMC) and shield systems

 Very good resistance to oils, coolants and lubricants

 Suited for applications in dragchains

UL UL - approved

 CAN-Bus

Connecting Options on request



- M12 connector**
- Customized lengths
 - 3-, 4-, 6- and 8-pole versions
 - Protection class IP68
 - Ordering codes of standard versions see ordering specifications

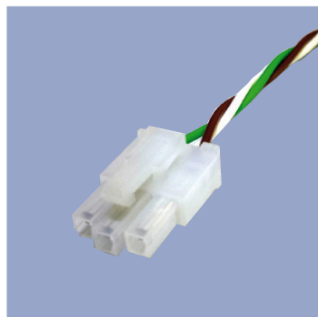

- Molex Mini Fit jr.**
- Customized length and lead wires
 - 3-, 4- and 6-pole versions
 - On request



- Tyco AMP Super Seal**
- Pin- and bushing housing
 - Customized lengths
 - 3-, 4- and 6-pole versions
 - Protection class IP67
 - On request



- Molex Mini Fit jr.**
- Customized length and lead wires
 - 3-, 4- and 6-pole versions
 - On request



- Deutsch DTM 04**
- Pin- and bushing housing
 - Customized lengths
 - 3-, 4- and 6-pole versions
 - Protection class IP67
 - On request



- ITT Cannon Sure Seal connector**
- Customized lengths
 - 3-, 4- and 6-pole versions
 - Protection class IP67
 - On request

Novotechnik U.S., Inc.
155 Northboro Road

Southborough, MA 01772
Phone 508 485 2244
Fax 508 485 2430
info@novotechnik.com
www.novotechnik.com



© Apr 10, 2026

The specifications contained in our datasheets are intended solely for informational purposes. The documented specification values are based on ideal operational and environmental conditions and can vary significantly depending on the actual customer application. Using our products at or close to one or more of the specified performance ranges can lead to limitations regarding other performance parameters. It is therefore necessary that the end user verifies relevant performance parameters in the intended application. We reserve the right to change product specifications without notice.