

**NOVOHALL
Rotary Sensor
Touchless**

RFX-6900
Heavy Duty
4 ... 20 mA

Mobile Applications

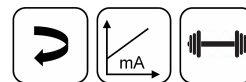

Special Features

- Very robust design for extreme environments
- Touchless hall technology
- Electrical range up to 360°, in single and dual-channel version
- 2 part design, mechanically decoupled
- Enhanced corrosion protection due to anodized aluminum housing, salt spray resistant
- Excellent linearity
- High Resolution to 12 bits
- Absolutely impermeable to splash-water IP69K
- High temperature resistance
- Suitable for use in safety-related applications according to ISO 13849
- For highest EMC requirements such as ISO pulses and interference fields according to ISO 11452 and ECE directive

Applications

- Position measurement in steering systems
- Pivotal vehicle bracings
- Transport systems with several steered axes
- Construction and agricultural machinery

The angle sensor RFX-6900 is designed for use in mobile applications under extreme environmental conditions. The sensor is suitable for a continuously ambitious operating.

The two-part design consisting of sensor and magnetic position marker offers great flexibility when mounting. The absence of shaft and bearing makes the assembly much less sensitive to axial and radial application tolerances - separate couplings are obsolete. Measurements can be made transmissively through any non-ferromagnetic material. The sensor is perfectly suitable for use in harsh environmental conditions through the completely encapsulated electronics.

The high accuracy and reliability of the magnetic angle measurement are further features, particularly in safety-related applications.

Description

| | |
|------------------------------|--|
| Material | Housing: aluminium AlMgSi1, anodized, salt spray resistant |
| Mounting | With 3 screws M4, screw-in depth 7 mm min. |
| Fastening torque of mounting | 250 ± 50 Ncm |
| Electrical connection | Connector M12x1, A-coded / Cable with cable screw connection, 4x 0.5 mm ² (AWG 20), TPE, unshielded |

Mechanical Data

| | |
|-------------------------|-----------------------|
| Dimensions | See dimension drawing |
| Mechanical travel | continuous |
| Weight (w/o connection) | approx. 200 g |

Ordering Specifications

Ordering Specifications

Preferred types printed in bold

- Delivery time up to 25 pcs. within 10 working days EXW
- Best low-volume pricing

Supply voltage U_b

3: $U_b = 12/24$ VDC

Output signal

2: 4 ... 20 mA

Other output signals on request

Output characteristic

1: **Rising characteristic cw**

2: Rising characteristic ccw

3: Crossed outputs, channel 1 rising cw (partly redundant) on request

4: **Crossed outputs, channel 1 rising cw (fully redundant)**

Other output characteristics on request

Electrical connection

Single-channel / partly redundant version: 1 output

252: 1x cable 4-pole, 2 m, unshielded

551: 1x connector M12, 4-pin, unshielded

Fully redundant version: 2 outputs

352: 2x cable 4-pole, 2 m, unshielded

651: 2x connector M12, 4-pin, unshielded

Cable versions and assembled connectors on request

R F X - 6 9 0 1 - 8 3 6 - 3 2 4 - 6 5 1

Series

Model / size

6901: 69 x 20.4 mm

Measuring range

06: Angle 60°

12: Angle 120°

18: Angle 180°

24: Angle 240°

30: Angle 300°

36: Angle 360°

Other angles on request

Number of channels

6: **Single-channel version (1x supply voltage U_b , 1x output)**

7: Partly redundant version (1x supply voltage U_b , 2x output) on request

8: **Fully redundant version (2x supply voltage U_b , 2x output)**

Drawing

CAD data see
www.novotechnik.de/en/download/cad-data/

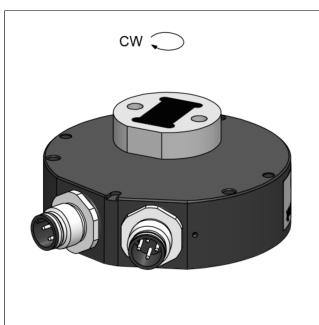
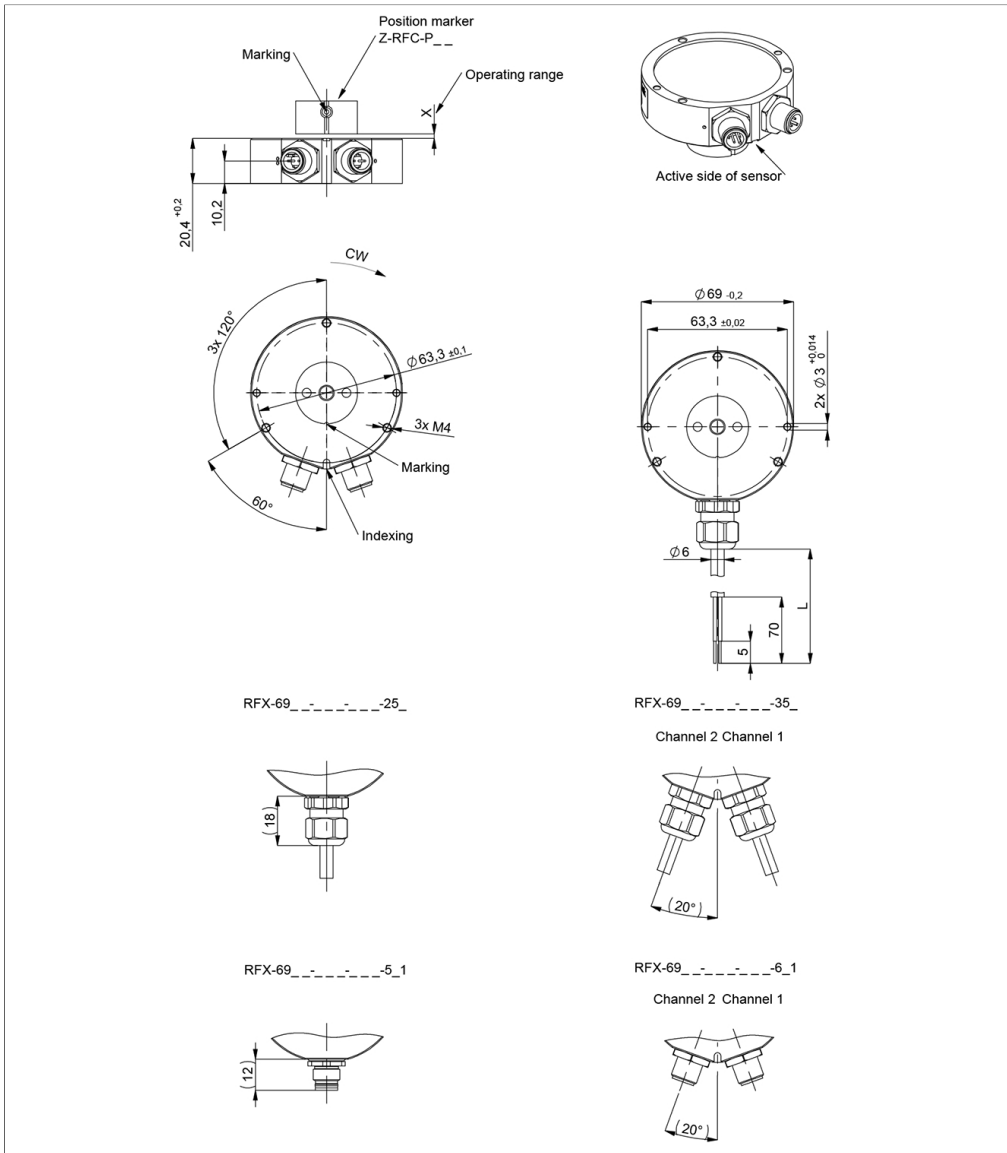

When the marking of the position marker is pointing towards the electrical outlet or to the indexing, the sensor output is near the electrical center position (index position).

Technical Data

| Type | RFX-69 _ _ - _ - _ - 32 _ - _ - _ - Analog current |
|---|--|
| Output signal | 4 ... 20 mA |
| Burden | ≤ 250 Ω (higher on request) |
| Number of channels | 1 / 2 |
| Update rate | 5 kHz |
| Measuring range | 60°, 120°, 180°, 240°, 300°, 360° |
| Independent linearity | ≤ ±0.5 %FS |
| Interlinearity | Measuring range < 90°: ±4 %FS, Measuring range ≥ 90°: ±2 %FS |
| Resolution | 12 bits |
| Repeatability | ≤ ±0.2° |
| Hysteresis | typ. < ±0.1° Only measuring range 360°: typ. < 0.25° (lower hysteresis on request) |
| Temperature error | Measuring range < 90°: 200 ppm/K, Measuring range ≥ 90°: 160 ppm/K |
| Supply voltage Ub | 12/24 VDC (9 ... 34 VDC) |
| Current consumption w/o load | typ. 20 mA per channel (Ub = 24 V) |
| Polarity protection | yes (supply lines) |
| Short circuit protection | yes (all outputs vs. GND and supply voltage) |
| Insulation resistance (500 VDC) | ≥ 10 MΩ |
| Environmental Data | |
| Max. operational speed | Mechanically unlimited |
| Vibration IEC 60068-2-6 | 20 g, 5 ... 2000 Hz, Amax = 0.75 mm |
| Shock IEC 60068-2-27 | 50 g, 6 ms |
| Protection class DIN EN 60529 | IP67 / IP69K (connector M12: IP67) |
| Operating temperature | -40 ... +85°C |
| Functional safety | Suitable for safety-related applications according to ISO 13849 after customer validation. Further safety data (DCavg...) and support for functional safety are available on request. |
| MTTF (IEC 60050) | 461 years (per channel) |
| MTTFd (EN ISO 13849-1 parts count method, w/o load) | 923 years (per channel) |
| MTTFd Declaration of Conformity | https://www.novotechnik.de/en/downloads/certificates/mttfd-certificate |
| Traceability | Serial number on type labeling: production batch of the sensor assembly and relevant sensor components |
| Conformity/Approval | CE, UKCA, E1 see https://www.novotechnik.de/en/downloads/certificates/declarations-of-conformity-eu/uk WEEE see https://www.novotechnik.de/en/downloads/certificates/eu-directive-weee/ |
| EMC Compatibility | |
| ISO 10605 ESD (Handling/Component) | 8 kV / 15 kV |
| ISO 11452-2 Radiated HF-fields | 100 V/m |
| ISO 11452-5 Radiated HF-Fields, stripline | 200 V/m |
| CISPR 25 Radiated emission | Level 5 |
| ISO 7637-2 Pulses on supply lines | (1, 2a, 2b, 3a, 3b, 4, 5) Level 4 |
| ISO 7637-3 Pulses on output lines | Level 4 |
| Emission/Immunity E1 | acc. to ECE-R10 (single-channel and fully redundant variants) |

FS = Full scale: Signal span according to electrical measuring range

Connection Assignment

| Signal | Connector code 5__ | Cable code 2__ | Connector code 5__ | Cable code 2__ | 2x Connector code 6__ | 2x Cable code 3__ |
|---------------------|-----------------------|-------------------|-----------------------|-------------------|--------------------------|----------------------|
| | Single-channel | Single-channel | Partly redundant | Partly redundant | Fully redundant | Fully redundant |
| Supply voltage Ub 1 | Pin 1 | GN | Pin 1 | GN | Channel 1 / Pin 1 | Channel 1 / GN |
| GND 1 | Pin 3 | BN | Pin 3 | BN | Channel 1 / Pin 3 | Channel 1 / BN |
| Signal output 1 | Pin 2 | WH | Pin 2 | WH | Channel 1 / Pin 2 | Channel 1 / WH |
| Signal output 2 | - | - | Pin 4 | YE | Channel 2 / Pin 4 | Channel 2 / YE |
| Supply voltage Ub 2 | - | - | - | - | Channel 2 / Pin 1 | Channel 2 / GN |
| GND 2 | - | - | - | - | Channel 2 / Pin 3 | Channel 2 / BN |
| Not assigned | Pin 4 | YE | - | - | Channel 1 / Pin 4 | Channel 1 / YE |
| | | | | | Channel 2 / Pin 2 | Channel 2 / WH |

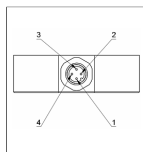
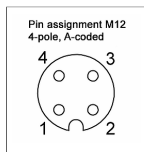

**Technical Data
Output
Characteristics**

Output characteristic

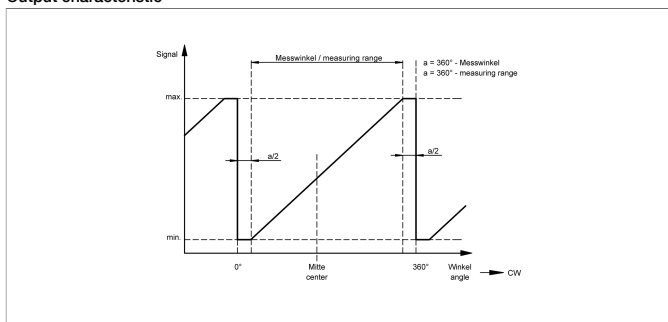

Output characteristic

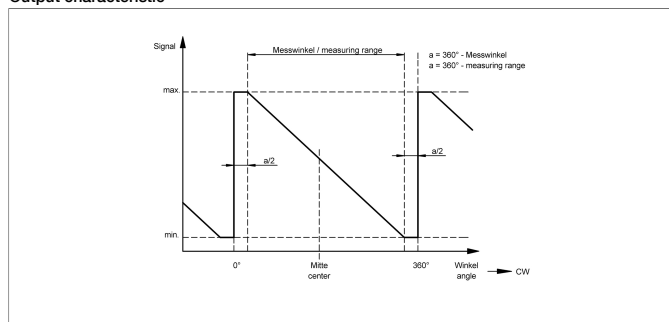

Output characteristic

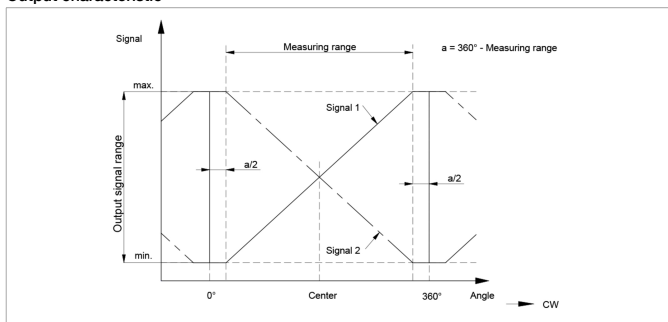

Output characteristic

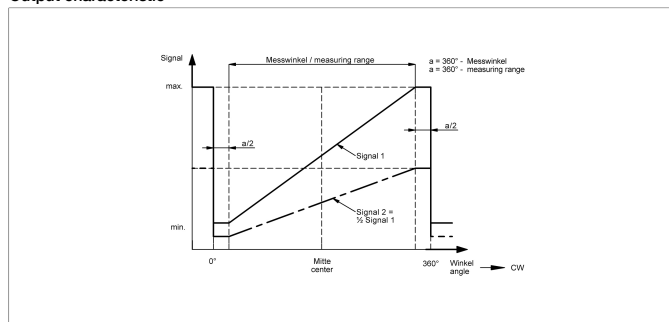

Output characteristic

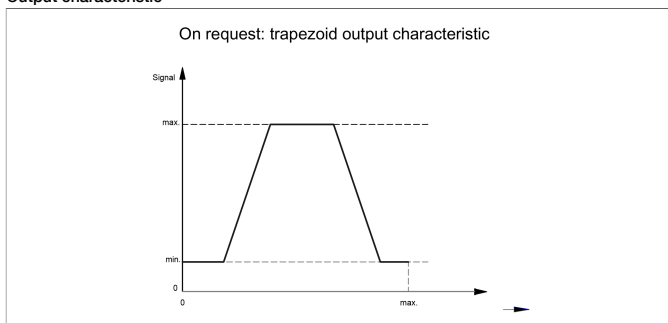

Output characteristic

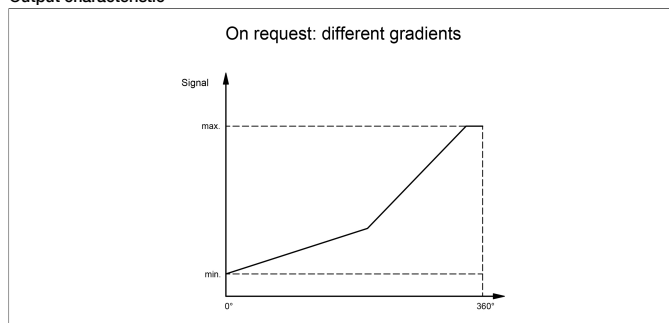

Output characteristic

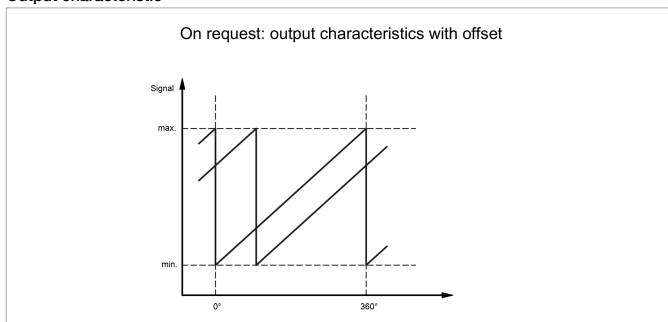

Output characteristic

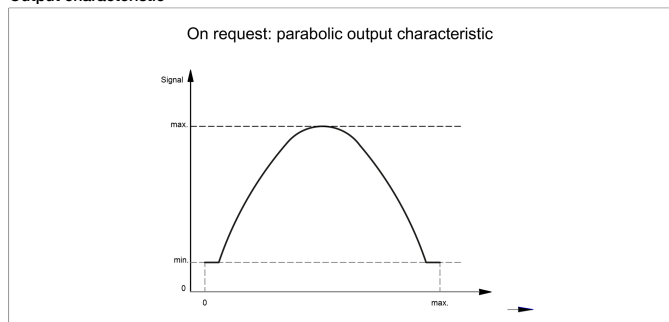

Position Markers

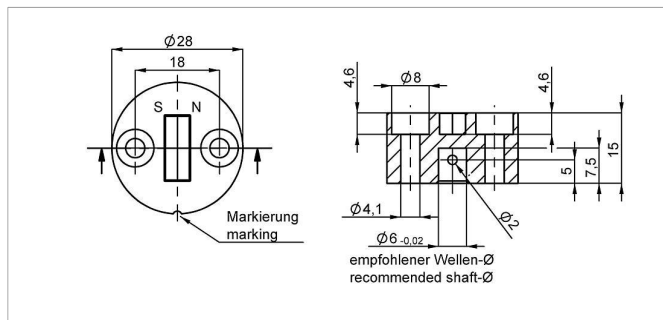

Z-RFC-P02

Position marker for frontal fixation with 2 cylinder head screws M4x20 (with screw lock) or with locking pin (both included in delivery).

Material PF
Max. permitted ± 3 mm
radial offset
Operating temp. $-40 \dots +125^\circ\text{C}$

| P/N | Pack. unit [pcs] |
|-----------|------------------|
| 40005661 | 1 |
| 400056080 | 25 |

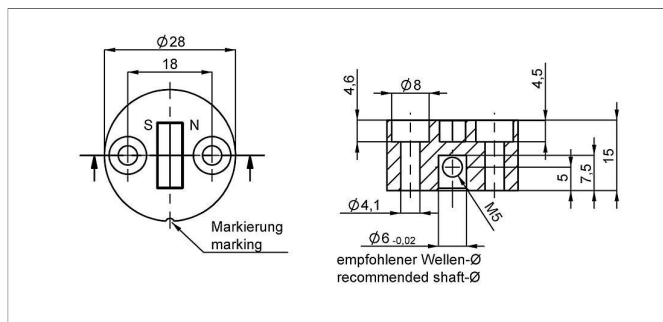

Z-RFC-P08

Position marker for fixation with threaded pin M5 (included in delivery).

Material PF
Max. permitted ± 3 mm
radial offset
Operating temp. $-40 \dots +125^\circ\text{C}$

| P/N | Pack. unit [pcs] |
|-----------|------------------|
| 400056070 | 1 |
| 400056084 | 25 |

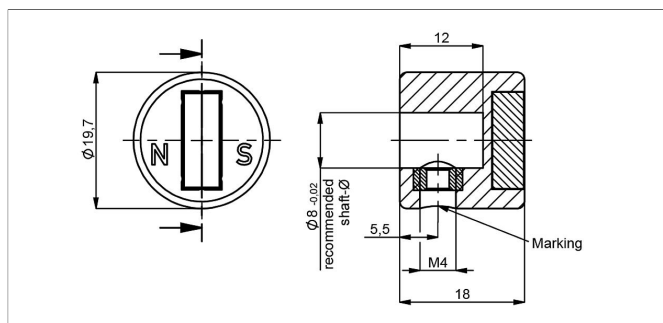

Z-RFC-P23

Position marker for fixation with threaded pin M4 (included in delivery)

Caution: For orientation of the output characteristic please follow the user manual of the position marker!

Material PA6-GF
Max. permitted ± 3 mm
radial offset
Operating temp. $-40 \dots +125^\circ\text{C}$

| P/N | Pack. unit [pcs] |
|-----------|------------------|
| 400056074 | 1 |
| 400056085 | 25 |

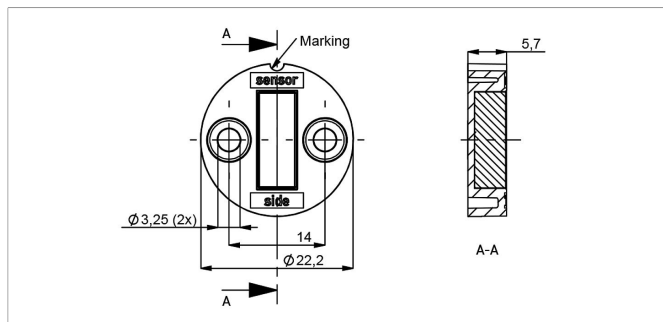

Z-RFC-P31

Position marker for frontal fixation with 2 cylinder screws M3x8 (included in delivery).

Material PBT-GF
Max. permitted ± 3 mm
radial offset
Operating temp. $-40 \dots +125^\circ\text{C}$

| P/N | Pack. unit [pcs] |
|-----------|------------------|
| 400056088 | 1 |
| 400056089 | 25 |

Position Markers

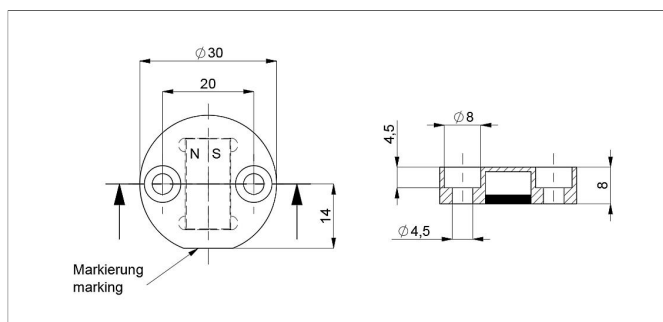
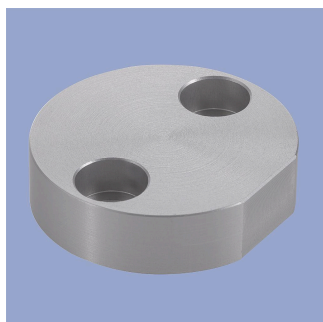

Z-RFC-P22

Position marker for frontal fixation with 2 cylinder head screws M4x20 (with screw lock, included in delivery).

Attention: Closed side of position marker faces the active side of sensor.

Material Aluminium, anodized
Max. permitted radial offset ± 4 mm
Operating temp. $-40 \dots +125^\circ\text{C}$

| P/N | Pack. unit [pcs] |
|-----------|------------------|
| 400106735 | 1 |
| 400106736 | 25 |

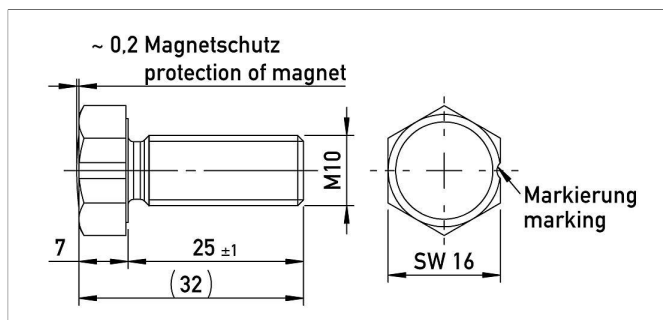

Z-RFC-P18

Screw position marker M10 x 25 mm, similar DIN 933, magnet potted

Material Aluminium, anodized
Max. permitted radial offset ± 3 mm
Operating temp. $-40 \dots +125^\circ\text{C}$

| P/N | Pack. unit [pcs] |
|-----------|------------------|
| 400104756 | 1 |
| 400104757 | 25 |

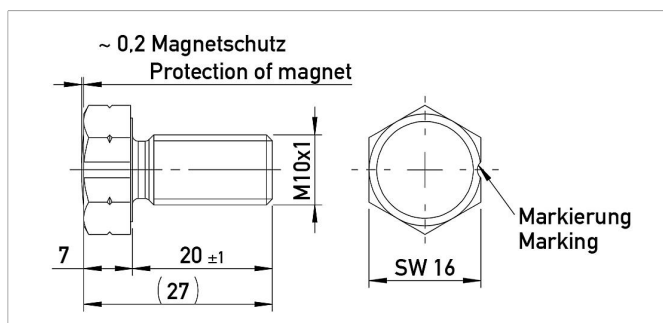

Z-RFC-P28

Screw position marker M10x1 x 20 mm, similar DIN 933, magnet potted

Material Aluminium, anodized
Max. permitted radial offset ± 3 mm
Operating temp. $-40 \dots +125^\circ\text{C}$

| P/N | Pack. unit [pcs] |
|-----------|------------------|
| 400108462 | 1 |
| 400108463 | 25 |

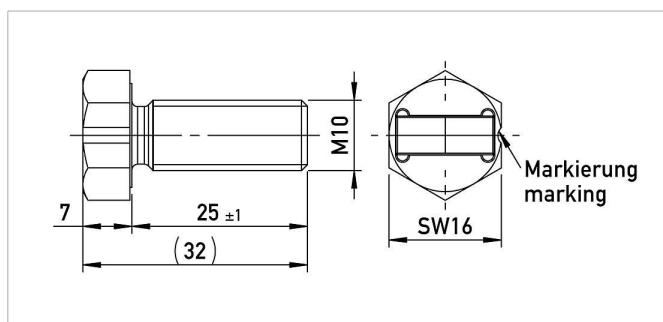

Z-RFC-P20

Screw position marker M10 x 25 mm, similar DIN 933

Material Aluminium, anodized
Max. permitted radial offset ± 3 mm
Operating temp. $-40 \dots +125^\circ\text{C}$

| P/N | Pack. unit [pcs] |
|-----------|------------------|
| 400104758 | 1 |
| 400104759 | 25 |

Position Markers

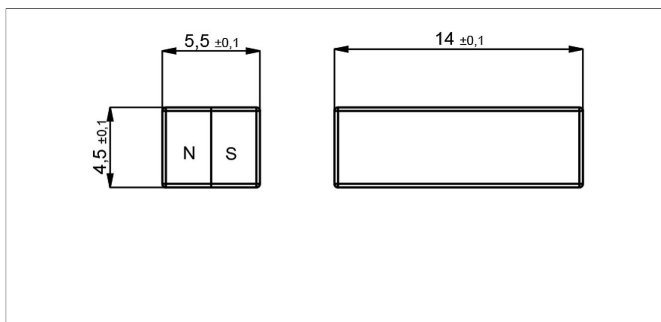

Z-RFC-P04

Magnet for direct application onto customer's shaft (see user manual).
We recommend mounting on non-magnetizable materials, otherwise the specified working distances will vary (e.g. reduction of approx. 20% with axial mounting on a magnetizable shaft).
Max. permitted radial offset ± 3 mm
radial offset
Operating temp. $-40 \dots +125^{\circ}\text{C}$

| P/N | Pack. unit [pcs] |
|-----------|------------------|
| 40005659 | 1 |
| 400056082 | 50 |

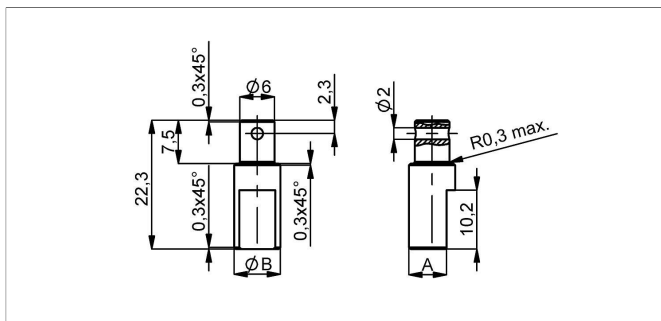
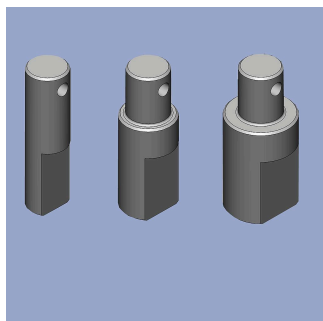

Z-RFC-S01/S02/S03

Shaft adapter for fixation at position marker Z-RFC-P02/P41 with locking pin

Material SS 1.4305 / AISI 303

| P/N | Type | ØB / A [mm] |
|-----------|-----------|-------------|
| 400056206 | Z-RFC-S01 | 6 / 4.5 |
| 400056207 | Z-RFC-S02 | 8 / 6.5 |
| 400056208 | Z-RFC-S03 | 10 / 8.5 |

Position Markers

Working Distances Position Markers [mm] - Redundant Versions

| Z-RFC-P02 / P04 / P08 Z-RFC-P20 / P23 / P31 | Z-RFC-P18 / P28 | Z-RFC-P22 |
|--|-----------------|-------------|
| 0.3 ... 3.5 | 0 ... 2.5 | 2.6 ... 7.3 |

Lateral Magnet Offset

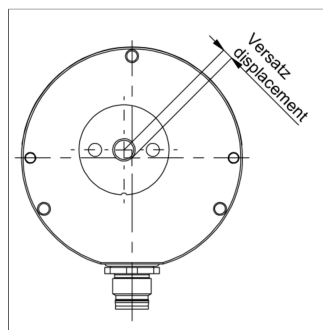

Lateral magnet offset will cause additional linearity error. The angle error, which is caused by radial displacement of sensor and position marker depends on the used position marker or magnet.

Additional Linearity Error at Radial Displacement - Single-channel Versions

| Z-RFC-P02 / P04 / P08 Z-RFC-P20 / P23 / P31 | Z-RFC-P18 / P28 | Z-RFC-P22 |
|--|-------------------------|-------------------------|
| 0.5 mm: $\pm 0.7^\circ$ | 0.5 mm: $\pm 1.1^\circ$ | 1.0 mm: $\pm 1.1^\circ$ |
| 1.0 mm: $\pm 1.8^\circ$ | 1.0 mm: $\pm 2^\circ$ | 2.0 mm: $\pm 2.4^\circ$ |
| 2.0 mm: $\pm 5.2^\circ$ | 2.0 mm: $\pm 4.6^\circ$ | 4.0 mm: $\pm 6.7^\circ$ |

Additional Linearity Error at Radial Displacement - Redundant Versions

| Z-RFC-P02 / P04 / P08 Z-RFC-P20 / P23 / P31 | Z-RFC-P18 / P28 | Z-RFC-P22 |
|--|-------------------------|-------------------------|
| 0.5 mm: $\pm 0.7^\circ$ | 0.5 mm: $\pm 1.1^\circ$ | 1.0 mm: $\pm 1.1^\circ$ |
| 1.0 mm: $\pm 1.8^\circ$ | 1.0 mm: $\pm 2^\circ$ | 2.0 mm: $\pm 2.4^\circ$ |
| 2.0 mm: $\pm 5.2^\circ$ | 2.0 mm: $\pm 4.6^\circ$ | 4.0 mm: $\pm 6.7^\circ$ |

Sensor Mounting

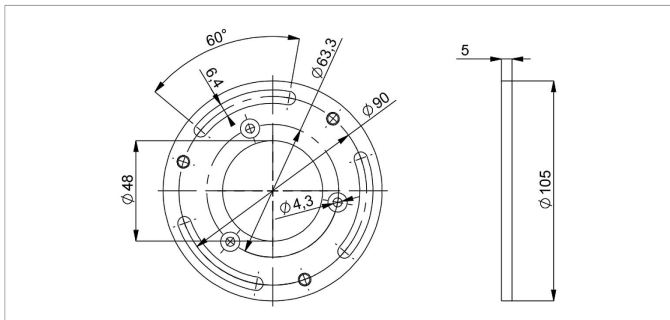
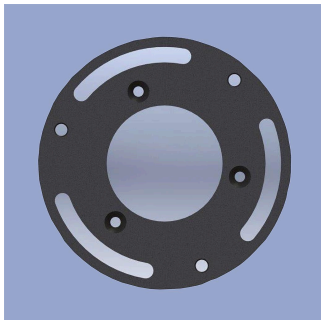

Z-RFX-M01
Mounting plate for adjustable mounting on screw-hole circle 90 mm. Assembly material (3x countersink screws) included in delivery
Material Aluminium, anodized
P/N **Type**
400104278 Z-RFX-M01

Connector System M12

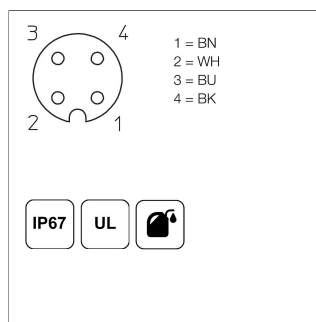
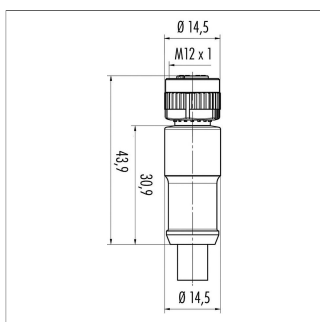

EEM-33-35/36/37
M12x1 Mating female connector, 4-pin, straight, A-coded, with molded cable, not shielded, IP67, open ended
Plug housing PA
Cable sheath PUR, Ø = max. 6 mm, -40 ... +85°C (fixed)
Lead wires PP, 0.34 mm²

| P/N | Type | Length |
|-----------|-----------|--------|
| 400056135 | EEM-33-35 | 2 m |
| 400056136 | EEM-33-36 | 5 m |
| 400056137 | EEM-33-37 | 10 m |

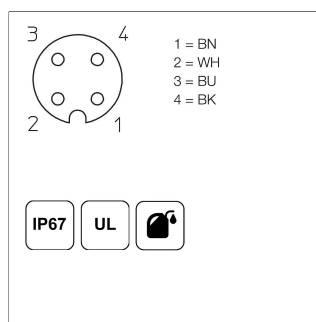
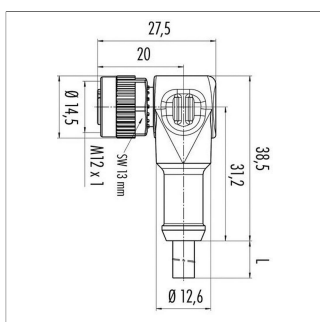

EEM-33-38/39/40
M12x1 Mating female connector, 4-pin, angled, A-coded, with molded cable, not shielded, IP67, open ended

Plug housing PA
Cable sheath PUR, Ø = max. 6 mm, -40 ... +85°C (fixed)
Lead wires PP, 0.34 mm²

| P/N | Type | Length |
|-----------|-----------|--------|
| 400056138 | EEM-33-38 | 2 m |
| 400056139 | EEM-33-39 | 5 m |
| 400056140 | EEM-33-40 | 10 m |

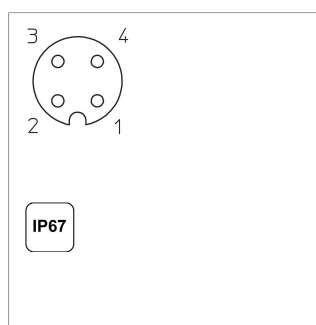
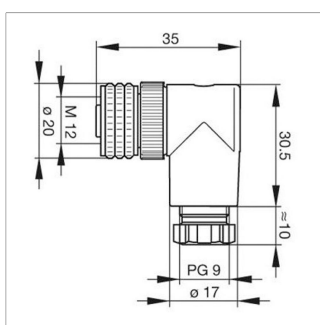

EEM-33-89
M12x1 Mating female connector, 4-pin, angled, A-coded, with coupling nut, screw termination, IP67, not shieldable
Operating temp. -25 ... +90°C
Plug housing PBT
For wire gauge 6 ... 8 mm, max. 0.75 mm²

| P/N | Type |
|-----------|-----------|
| 400005634 | EEM-33-89 |

IP67 Protection class IP67 DIN EN 60529

IP68 Protection class IP68 DIN EN 60529

 Very good Electromagnetic Compatibility (EMC) and shield systems

 Very good resistance to oils, coolants and lubricants

C Suited for applications in dragchains

UL UL - approved

 CAN-Bus

Novotechnik U.S., Inc.
155 Northboro Road

Southborough, MA 01772
Phone 508 485 2244
Fax 508 485 2430
info@novotechnik.com
www.novotechnik.com



© Nov 5, 2025

The specifications contained in our datasheets are intended solely for informational purposes. The documented specification values are based on ideal operational and environmental conditions and can vary significantly depending on the actual customer application. Using our products at or close to one or more of the specified performance ranges can lead to limitations regarding other performance parameters. It is therefore necessary that the end user verifies relevant performance parameters in the intended application. We reserve the right to change product specifications without notice.