

## Signal Conditioners for potentiometric Position Measurement

### MUP-410



#### Special features

- Processor controlled interface module for potentiometric position sensors
- Simple teach-in function to adapt to the travel of the connected potentiometer
- Configuration of output signals via DIP switches
- Over/underflow signaling of learned range
- high measuring rate - up to 7.2 kHz
- 24 bit Sigma-Delta-AC converter
- Electrical Isolation (DC/DC transformers)
- Standardized output signals  
0 ... 2/5/10 V  
±10 V  
4 ... 20 mA  
0 ... 5/20 mA
- Outstanding linearity
- Extremely low temperature drift typ. < 15 ppm/K
- Designed for standard DIN EN 60175 mounting rail fixture

Processor controlled signal transformer for potentiometric input signals to be converted to standardized voltage or current signals. The signal conditioner supplies the potentiometric sensors with a highly stable constant voltage.

The potentiometer signal is sampled without load via a high-resistance input stage and transformed into a proportional standardized output signal.

The adjustment of the desired output signal (current or voltage, switchable by DIP switches) is done easily by a teach-in procedure using only 2 buttons on the front panel of the device. The input span can be limited down to 80 % of the total input range. This permits standardized output signals to be adjusted if the maximum travel or angle of the sensor is not completely utilized.

The electronic circuitry is accommodated in a plastic housing designed for mounting to a standard DIN EN 60175 mounting rail. The wide operating voltage range allows the use of unstabilized power sources.

The excellent linearity and temperature drift characteristics ensure optimum electrical implementation of potentiometers. By locating the MUP-410 physically close to the potentiometer, reliable and interference-free transmission of the position signal is guaranteed, even over long transmission distances.

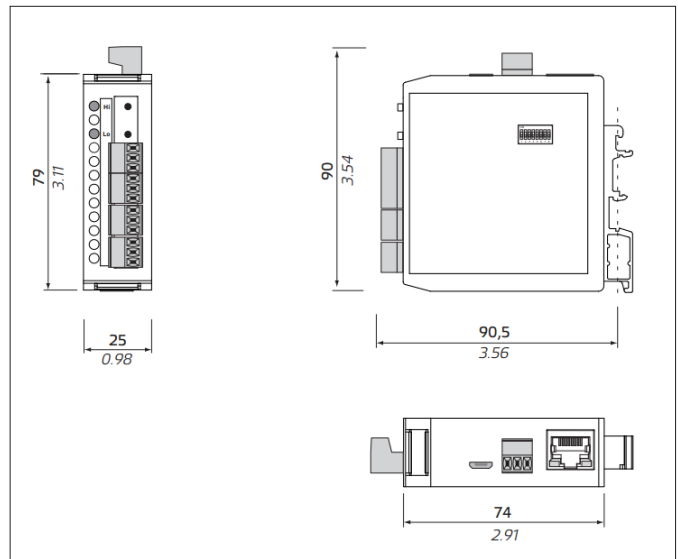

#### Mechanical Data

Dimensions	90.5 x 79 x 25 mm
Terminals	connector terminal, 1.5 mm <sup>2</sup> (AWG 14)
Rail mounting	35 mm (DIN EN 60175)
Material	PA66, incombustible UL94V-0, green

#### Electrical Data

Supply voltage	10 ... 30 VDC
Power drain	< 2.5 W
Accuracy	±0.02 %FS 0 ... 5 V: ±0.03 %FS 0 ... 2 V/ 0 ... 5 mA: ±0.05 %FS
Temperature coefficient	max. 20 ppm/K
Functions	Teach-In, Tara
Konfiguration	Output signal and measurement rate configurable via DIP switches
Output signals	4 ... 20 mA (default) 0 ... 2/5/10 V ±10 V 0 ... 5/20 mA
Allowed potentiometer resistance	≥ 500 Ω
Burden current output	≤ 500 Ω
Load voltage output	≥ 1kΩ
Response time	< 160 μs
Stabilization period	5 minutes after power on
Resolution teach-in	16 Bit

#### Environmental Data

Protection class	IP20
Operating temperature	-20 ... +60°C
Storage temperature	-20 ... +85°C
EMC	EN 61326-1
Electrical safety	EN 61010-1, A2



© 11/2025

## Connection Assignment

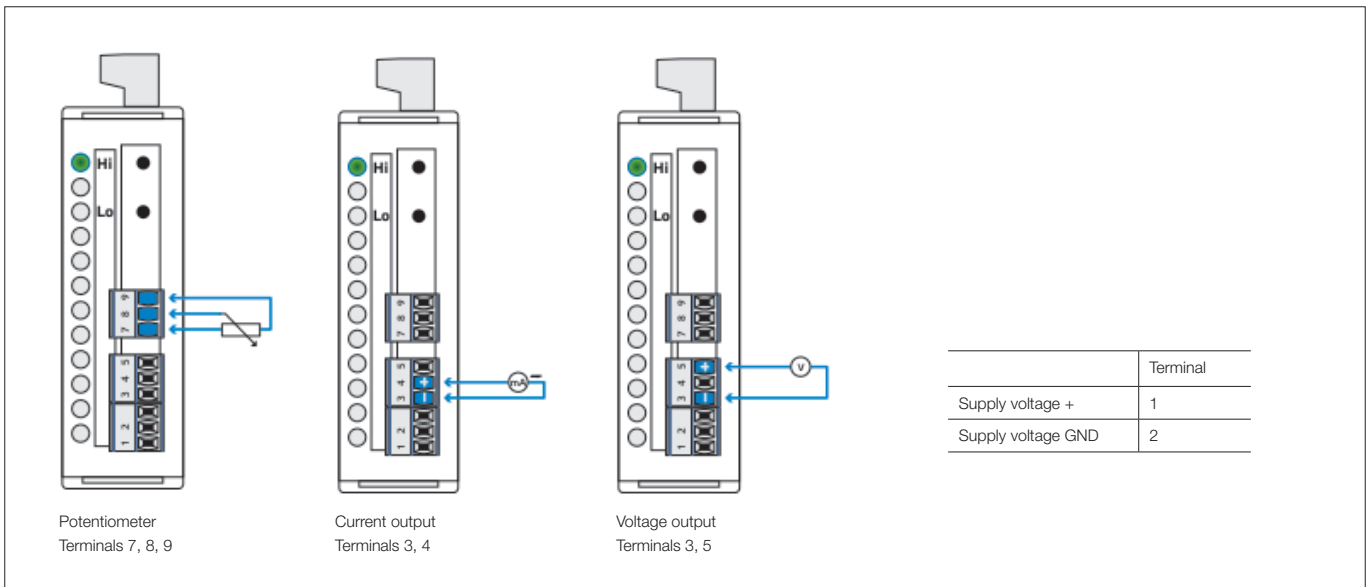

## Ordering Specifications

**M U P - 4 1 0 - 1 1**

<p>Series</p>	<p>Type</p>	<p><b>Configuration</b></p> <p>11: 4 ... 20 mA (default) P/N 400108799          Configurable via DIP switches: 0 ... 2/5/10 V            ±10 V            0 ... 5/20 mA</p> <p>Digital interfaces on request:</p> <ul style="list-style-type: none"> <li>• RS485</li> <li>• Modbus</li> <li>• USB</li> </ul>
---------------	-------------	--

The specifications contained in our datasheets are intended solely for informational purposes. The documented specification values are based on ideal operational and environmental conditions and can vary significantly depending on the actual customer application. Using our products at or close to one or more of the specified performance ranges can lead to limitations regarding other performance parameters. It is therefore necessary that the end user verifies relevant performance parameters in the intended application. We reserve the right to change product specifications without notice.